

Glass



Furnaces and Heat Treatment Plants for

**Annealing, Hardening, Tempering
Bending, Slumping, Annealing
Welding
Laminating
Fusing
Melting
Photovoltaics
Quartz Glass Technology
Fiber Optics
Heat Soak
Laboratory**

www.nabertherm.com

■ Made
■ in
■ Germany



Made in Germany

Nabertherm with 480 employees worldwide have been developing and producing industrial furnaces for many different applications for over 60 years. As a manufacturer, Nabertherm offers the widest and deepest range of furnaces worldwide. 150,000 satisfied customers in more than 100 countries offer proof of our commitment to excellent design, quality and cost efficiency. Short delivery times are ensured due to our complete inhouse production and our wide variety of standard furnaces.

Setting Standards in Quality and Reliability

Nabertherm does not only offer the widest range of standard furnaces. Professional engineering in combination with inhouse manufacturing provide for individual project planning and construction of tailor-made thermal process plants with material handling and charging systems. Complete thermal processes are realized by customized system solutions.

Innovative Nabertherm control technology provides for precise control as well as full documentation and remote monitoring of your processes. Our engineers apply state-of-the-art technology to improve the temperature uniformity, energy efficiency, reliability and durability of our systems with the goal of enhancing your competitive edge.

Global Sales and Service Network – Close to you

Nabertherm's strength is one of the biggest R&D department in the furnace industry. In combination with central manufacturing in Germany and decentralized sales and service close to the customer we can provide for a competitive edge to live up to your needs. Long term sales and distribution partners in all important world markets ensure individual on-site customer service and consultation. There are various reference customers in your neighborhood who have similar furnaces or systems.



Large Customer Test Center

Which furnace is the right choice for this specific process? This question cannot always be answered easily. Therefore, we have set up our modern test center which is unique in respect to size and variety. A representative number of furnaces is available for tests for our customers.

Customer Service and Spare Parts

Our professional service engineers are available for you worldwide. Due to our complete inhouse production, we can despatch most spare parts from stock over night or produce with short delivery time.

Experience in Many Fields of Thermal Processing

In addition to furnaces for the glass industry, Nabertherm offers a wide range of standard furnaces and plants for many other thermal processing applications. The modular design of our products provides for customized solutions to your individual needs without expensive modifications.

Table of Contents

	Page
Forced Convection Furnaces, Clean Room Solutions	
Forced convection bogie hearth furnaces , electrically heated or gas-fired.....	4
Forced convection chamber furnaces, heat soak test furnaces for toughened safety glass (TSG) electrically heated or gas-fired	6
Chamber ovens, ovens for laminated safety glass (LSG), electrically heated or gas-fired	8
Clean Room Solutions	11
Ovens, also with safety technology according to EN 1539, electrically heated	12
Forced convection chamber furnaces, electrically heated	14
Furnaces with Radiation Heating	
Bogie hearth furnaces with wire heating up to 1400 °C.....	16
High-temperature bogie hearth furnaces with SiC rod heating up to 1550 °C	19
Chamber furnaces with wire heating up to 1400 °C	20
Chamber furnaces with brick insulation or fiber insulation	22
Top hat furnaces or bottom loading furnaces with wire heating up to 1400 °C	24
Top hat furnaces with SiC rod heating	26
Pit-type and top-loading furnaces with or without air circulation, electrically heated or gas-fired	27
High-Temperature Furnaces	
High-temperature furnaces with molybdenum disilicide heating elements with fiber insulation up to 1800 °C..	28
High-temperature furnaces with SiC rod heating up to 1550 °C	31
High-temperature furnaces with molybdenum disilicide heating elements with refractory brick insulation up to 1700 °C	32
High-temperature furnaces up to 1600 °C	33
Top hat furnaces or bottom loading furnaces with molybdenum disilicide heating elements up to 1800 °C	34
Continuous Furnaces, Electrically Heated or Gas-Fired	38
Salt-Bath Furnaces for Chemical Hardening of Glass	42
Chamber Furnaces, Electrically Heated	43
Fusing Furnaces, Tub Furnaces and Top Hat Furnaces	
Fusing furnaces with fixed table	44
Fusing furnaces with wire heating with movable table	43
Tub furnaces with wire heating	48
Top hat furnaces with wire heating with table.....	50
Retort Furnaces up to 1100 °C resp. 3000 °C	
Hot-wall retort furnaces up to 1100 °C	52
Cold-wall retort furnaces up to 2400 °C or up to 3000 °C	56
Bottom loading retort furnace up to 2400 °C	61
Catalytic and Thermal Post Combustion, Exhaust Gas Washer	62
Tube Furnaces	
Rotary tube furnaces for continuous processes up to 1300 °C.....	64
Customized tube furnaces.....	66
High-temperature tube furnaces for horizontal and vertical operation up to 1800 °C, gas atmosphere or vacuum	67
Float-Glass Test Kiln with Wire Heating	68
Laboratory Melting Furnace SC 8 with SiC Rod Heating	68
Fast-Firing Decorating Furnaces with Infrared Heating	69
Glass Melting Furnaces	70
Temperature Uniformity and System Accuracy	71
Process Control and Documentation	72



Forced Convection Bogie Hearth Furnaces

Electrically Heated or Gas-Fired



Forced convection bogie hearth furnace W 19150/60AS for tempering of semi-finished borosilicate glass products

The forced convection bogie hearth furnaces W 1000/60A - W 8300/85A are used when heavy charges weighing up to more than 25 t have to be heat-treated. They are ideal for processes such as solution like glass tempering or cooling from glass, for which a good temperature uniformity is crucial. The high-performance air circulation assures that the temperature uniformity achieved throughout the work space is outstanding. A broad selection of additional equipment enables these bogie hearth furnaces to be optimally adapted to suit specific processes.



Cooling fan for accelerated cooling

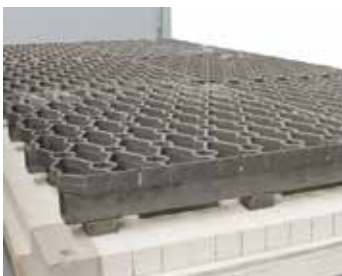

Charging grid in a forced convection bogie hearth furnace for even load distribution

- Tmax 600 °C or 850 °C
- Dual shell housing with rear ventilation provides for low shell temperatures for the 850 °C models
- Swing door hinged on the right side
- Heating from chrome steel heating elements for the 600 °C models
- Heating from three sides (both side walls and the trolley) for the 850 °C models
- High-performance air circulation fan with vertical circulation
- Temperature uniformity up to +/- 5 °C according to DIN 17052-1 see page 71
- Bottom heating protected by SiC tiles on the bogie providing level stacking surface for the 850 °C models
- Furnace chamber fitted with inner sheets made of stainless steel 1.4301 for 600 °C models and of 1.4828 for 850 °C models
- Insulation structured with high-quality mineral wool for 600 °C models
- Insulation made of high-quality, non-classified fiber material for 850 °C models
- Bgies with flanged wheels running on rails for easy and precise movement of heavy loads
- Electric chain-driven bogie in combination with rail operation for smooth movement of heavy loads from model W 4800
- Over-temperature limiter with adjustable cutout temperature for thermal protection class 2 in accordance with EN 60519-2 as temperature limiter to protect the furnace and load
- Defined application within the constraints of the operating instructions
- NTLog Basic for Nabertherm controller: recording of process data with USB-flash drive
- Controls description see page 72

Additional equipment

- Direct gas heating or upon request with indirect gas heating with radiation tube
- Electric chain-driven bogie in combination with rail operation for smooth movement of heavy loads up to Model W 4000
- Optimization of the temperature uniformity up +/- 3 °C according to DIN 17052-1 see page 71
- Bogie running on steel wheels with gear rack drive, no rails in front of the furnace necessary
- Different possibilities for an extension to a bogie hearth furnace plant:
 - Additional bogies
 - Bogie transfer system with parking rails to exchange bogies running on rails or to connect multiples furnaces
 - Motor-driven bogies and cross-traversal system
 - Fully automatic control of the bogie exchange
- Electro-hydraulic lift door
- Motor-driven exhaust air flaps, adjustable via the program
- Uncontrolled or controlled cooling system with frequency-controlled cooling fan and motor-driven exhaust air flap
- Multi-zone control adapted to the particular furnace model provides for optimum temperature uniformity in the 850 °C models
- Commissioning of the furnace with test firing and temperature uniformity measurement (also with load) for the purpose of process optimization
- Designed for Tmax 950 °C, fan blade driven indirectly via a belt to protect the air recirculation motor against over-heating
- Process control and documentation via VCD software package or Nabertherm Control Center (NCC) for monitoring, documentation and control see page 72



Forced convection bogie hearth furnace W 10430/85AS



Forced convection bogie hearth furnace W 3300/85S with chain drive

Model	Tmax °C	Inner dimensions in mm			Volume in l	Outer dimensions in mm			Heating power in kW ¹	Electrical connection*
		w	d	h		W	D	H		
W 1000/.. A	600 or 850	800	1600	800	1000	1800	2390	2305	45	3-phase
W 1600/.. A		1000	1600	1000	1600	2000	2390	2535	45	3-phase
W 2200/.. A		1000	2250	1000	2200	2000	3040	2535	90	3-phase
W 3300/.. A		1200	2250	1200	3300	2200	3040	2745	90	3-phase
W 4000/.. A		1500	2250	1200	4000	2500	3040	2780	110	3-phase
W 4800/.. A		1200	3300	1200	4800	2200	4090	2780	110	3-phase
W 6000/.. A		1500	3300	1200	6000	2500	4090	2900	140	3-phase
W 6600/.. A		1200	4600	1200	6600	2200	5390	2770	140	3-phase
W 7500/.. A		1400	3850	1400	7500	2400	4640	2980	140	3-phase
W 8300/.. A		1500	4600	1200	8300	2500	5390	2780	185	3-phase

¹Depending on furnace design connected load might be higher

*Please see page 73 for more information about supply voltage

Forced Convection Chamber Furnaces, Heat Soak Test Furnaces for Toughened Safety Glass (TSG) Electrically Heated or Gas-Fired



Forced convection chamber furnace N 4010/45 HA



Forced convection chamber furnace N 12000/26 HA

These forced convection chamber furnaces are available for maximum working temperatures of 260 °C or 450 °C. They are suitable for numerous processes such as pre-heating of moulds, ageing or drying.

These forced convection chamber furnaces up to 450 °C are recommended for Heat Soak testing of Toughened Safety Glass (TSG). During a Heat Soak Test in accordance with EN 14179-1 the panes are exposed to a temperature of 290 °C for at least four hours in order to transform nickel sulfide inclusions and hence to prevent the pane from breaking spontaneously later. The documentation of the heat treatment process is strongly recommended. Program entry, visualization and the documentation of the process are achieved by means of the PLC-control in combination with the powerful Nabertherm Control Center (NCC), which registers and archives the temperatures at different measuring points on the pane.

Standard version

- Tmax 260 °C or 450 °C
- Electrically heated or gas-fired
- Heating of the electrically heated furnace by means of heater coils
- Direct gas-fired or up on request with indirect gas heating with radiation tube, e.g. for heat treatment of aluminum
- Optimal air circulation for your charge by means of adjustable air outlets
- Horizontal air circulation (type ../HA)
- High air exchange for perfect heat transfer
- Ground level charging without bottom insulation for 260 °C models
- Temperature uniformity up to +/- 5 °C according to DIN 17052-1 see page 71
- Furnace chamber lined with alloy 1.4301 (DIN)
- High quality mineral wool insulation provides for low outer temperatures
- Inside unlocking device for furnaces with walk-in work space
- Furnace sizes suitable for common charging systems, such as pallets, baskets, etc.
- Double-wing door for furnaces with an internal width of more than 1500 mm (260 °C and 450 °C models).
Furnaces for higher temperatures and with smaller sizes are equipped with a single-wing door.
- Over-temperature limiter with adjustable cutout temperature for thermal protection class 2 in accordance with EN 60519-2 as temperature limiter to protect the furnace and load
- Defined application within the constraints of the operating instructions
- NTLLog Basic for Nabertherm controller: recording of process data with USB-flash drive
- Controls description see page 72



Forced convection chamber furnace N 2880/60HAS for glass cooling with frame for opening of individual chamber segments



Adjustable air outlets for optimization of the temperature uniformity



Forced convection chamber furnaces
N 10000/45HA

Additional equipment

- Optional floor insulation provides for improved temperature uniformity for 260 °C models
- Data recording via Nabertherm Control Center (NCC) in accordance with the requirements of EN 14179-1 for Heat Soak Tests of Tempered Safety Glass (TSG)
- Racks for loading of standing glass panes
- Entry ramps or track cutouts for floor-level charging cart of models with bottom insulation
- Furnace positioned on base frame provides for ergonomic charging height
- Electro-hydraulic lift door
- Fan system for faster cooling with manual or motor-driven control
- Motor-driven control of air inlet and exhaust air flaps for better ventilation of the furnace chamber
- Observation window and/or furnace chamber lighting
- Optimization of the temperature uniformity up to +/- 3 °C according to DIN 17052-1 see page 71
- Safety technology according to EN 1539 for charges containing solvents
- Charging systems or roller conveyors, also electrically driven provide for easy charging
- Catalytic or thermal exhaust gas cleaning systems
- Process control and documentation via VCD software package or Nabertherm Control Center (NCC) for monitoring, documentation and control see page 72



Loading rack for glass panes

Model	Tmax °C	Inner dimensions in mm			Volume in l	Circulation rate m³/h	Heating power in kW²		Electrical connections*
		w	d	h			260 °C	450 °C	
N 9900/.. A	260 or 450	1500	3000	2200	9900	21500	85	85¹/100	3-phase
N 17600/.. A	260 or 450	2000	4000	2200	17600	33000	130	130¹/145	3-phase
N 41600/.. A	260 or 450	2000	6500	3200	41600	64000	200	200¹/230	3-phase
N 1000/..	260 or 450	1000	1000	1000	1000	3600	15	15¹/ 36	3-phase
N 1500/..	260 or 450	1500	1000	1000	1500	3600	18	18¹/ 36	3-phase
N 1500/..1	260 or 450	1000	1500	1000	1500	3600	18	18¹/ 36	3-phase
N 2000/..	260 or 450	1500	1100	1200	2000	6400	18	18¹/ 42	3-phase
N 2000/..1	260 or 450	1100	1500	1200	2000	6400	18	18¹/ 42	3-phase
N 2010/..	260 or 450	1000	1000	2000	2000	7200	24	24¹/ 48	3-phase
N 2880/..	260 or 450	1200	1200	2000	2880	7200	48	48¹/ 60	3-phase
N 4000/..	260 or 450	1500	2200	1200	4000	9000	42	42¹/ 60	3-phase
N 4000/..1	260 or 450	2200	1500	1200	4000	9000	42	42¹/ 60	3-phase
N 4010/..	260 or 450	1000	2000	2000	4000	12800	48	48¹/ 60	3-phase
N 4010/..1	260 or 450	2000	1000	2000	4000	12800	48	48¹/ 60	3-phase
N 4500/..	260 or 450	1500	1500	2000	4500	12800	48	48¹/ 60	3-phase
N 5600/..	260 or 450	1500	2500	1500	5600	12800	60	60¹/ 84	3-phase
N 6750/..	260 or 450	1500	3000	1500	6750	19200	90	90¹/108	3-phase
N 7200/..	260 or 450	2000	1500	2400	7200	18000	84	84¹/108	3-phase
N 10000/..	260 or 450	2000	2500	2000	10000	25600	96	96¹/120	3-phase

¹Reduced connected load for plastics applications

²Depending on furnace design connected load might be higher

*Please see page 73 for more information about supply voltage



Temperature recording in accordance with
EN 14179-1

Chamber Ovens, Ovens for Laminated Safety Glass (LSG)

Electrically Heated or Gas-Fired



Chamber oven KTR 1500



Chamber oven KTR 4500



Chamber oven KTR 6125

The chamber ovens of the KTR range can be used for complex drying processes and heat treatment of charges to an application temperature of 260 °C. The high-performance air circulation enables optimum temperature uniformity throughout the work space. A wide range of accessories allow the chamber ovens to be modified to meet specific process requirements. The design for the heat treatment of flammable materials in conformance with EN 1539 (NFPA 86) is available for all sizes.

The chamber ovens can also be used for production of laminated safety glass (LSG). During this process two panes are bonded using a laminating foil and entered into the oven inside a vacuum bag. From outside the furnace a vacuum is generated via hose connection in order to avoid air inclusions between the panes during the heat treatment.



Chamber oven KTR 1500 with charging cart

- Tmax 260 °C
- Electrically heated (via a heating register with integrated chrome steel heating elements) or gas-fired (direct or indirect gas-fired including injection of the hot air into the intake duct)
- Temperature uniformity up to +/- 3 °C according to DIN 17052-1 (for design without track cutouts) see page 71
- High-quality mineral wool insulation provides for outer temperatures of < 25 °C above room temperature
- High air exchange for fast drying processes
- Double-wing door for furnaces KTR 3100 and larger



Chamber oven KTR 22500/S with chamber lightning and drive-in tracks with insulated plugs which provide for an optimal temperature uniformity

- Over-temperature limiter with adjustable cutout temperature for thermal protection class 2 in accordance with EN 60519-2 as temperature limiter to protect the oven and load
- Incl. floor insulation
- Defined application within the constraints of the operating instructions
- NTLog Basic for Nabertherm controller: recording of process data with USB-flash drive
- Controls description see page 72

Additional equipment

- Track cutouts for level drive-in of charging cart
- Connection ports for vacuum bags inside the oven for laminated safety glass (LSG). The vacuum pump is connected on the outside of the furnace.
- Base frame to charge the oven via a charging forklift
- Additional Door in the back for charging from both sides or to use the oven as lock between two rooms
- Fan system for faster cooling with manual or motor-driven control of the exhaust air flaps
- Programmed opening and closing of exhaust air flaps
- Air circulation with speed control, recommendable for processes with light or sensitive charge
- Observation window and furnace chamber lighting
- Safety technology according to EN 1539 (NFPA 86) (models KTR .. LS) for charges containing solvents
- Charging cart with or without rack system
- Design for clean room heat treatment processes see page 11
- Rotating systems for tempering processes
- Process control and documentation via VCD software package or Nabertherm Control Center (NCC) for monitoring, documentation and control see page 72



KTR 3100/S for curing of composites in vacuum bags incl. pump and necessary connections in the oven chamber



Direct gas-firing at a chamber dryer

Chamber Ovens, Ovens for Laminated Safety Glass (LSG)

Electrically Heated or Gas-Fired



KTR 4500 with platform cart, inner lightning and observation windows



Charging cart with pull-out trays



Drive-in tracks with sealing shoes

Accessories

- Adjustable plate shutters to adapt the air guide to the charge and improve temperature uniformity
- Guide-in tracks and shelves
- Shelves with 2/3 extraction with evenly distributed load on the whole shelf surface
- Platform cart in combination with drive-in tracks
- Charging cart with rack system in combination with drive-in tracks
- Sealing shoes for ovens with drive-in tracks to improve temperature uniformity in the work space

All KTR-models are also available with Tmax 300 °C.



Pull-out shelves, running on rolls

Model	Tmax °C	Inner dimensions in mm			Volume in l	Outer dimensions in mm ²			Heating power in kW ¹ KTR/KTR ..LS	Electrical connection*
		w	d	h		W	D	H		
KTR 1000 (LS)	260	1000	1000	1000	1000	1900	1430	1815	18/on request	3-phase
KTR 1500 (LS)	260	1000	1000	1500	1500	1900	1430	2315	18/36	3-phase
KTR 3100 (LS)	260	1250	1250	2000	3100	2150	1680	2905	27/45	3-phase
KTR 4500 (LS)	260	1500	1500	2000	4500	2400	1930	2905	45/54	3-phase
KTR 6125 (LS)	260	1750	1750	2000	6125	2650	2200	3000	45/63	3-phase
KTR 6250 (LS)	260	1250	2500	2000	6250	2150	3360	3000	54/on request	3-phase
KTR 8000 (LS)	260	2000	2000	2000	8000	2900	2450	3000	54/81	3-phase
KTR 9000 (LS)	260	1500	3000	2000	9000	2400	3870	3000	72/on request	3-phase
KTR 12300 (LS)	260	1750	3500	2000	12300	2650	4400	3000	90/on request	3-phase
KTR 16000 (LS)	260	2000	4000	2000	16000	2900	4900	3000	108/on request	3-phase
KTR 21300 (LS)	260	2650	3550	2300	21300	3750	4300	3500	108/on request	3-phase
KTR22500 (LS)	260	2000	4500	2500	22500	2900	5400	3500	108/on request	3-phase

¹Depending on furnace design connected load might be higher

²Outer dimensions from chamber ovens KTR .. LS are different

*Please see page 73 for more information about supply voltage

Clean Room Solutions

Clean room applications impose particularly high requirements to the design of the chosen furnace. If the complete furnace is operated in a clean room an essential contamination of the clean room atmosphere must be avoided. Especially, the particle contamination must be reduced to a minimum.

The specific application determines the choice of the required furnace technology. In many cases forced convection furnaces are required to achieve the necessary temperature uniformity at lower temperatures. For higher temperatures, Nabertherm has also delivered many furnaces with radiant heating.

Furnace Installation in the Clean Room

If the complete furnace is supposed to be positioned in the clean room, then it is important that both the furnace chamber and the furnace housing as well as the controls provide for good protection against contamination. Surfaces must be easy to clean. The furnace chamber is tightly sealed to the insulation behind it. If necessary, additional equipment such as filters for the fresh air supply or the air circulation in the furnace can be used to improve the cleanliness class. It is recommended to install the switchgear and the furnace controls outside the clean room.



KTR 8000 designed as a production oven in the clean room with filters for air circulation

Furnace Installation in the Grey Room, Furnace Charging from the Clean Room

Optimal results with respect to cleanness will be achieved by placing the furnace in the grey room with charging from the clean room. This significantly reduces the amount of costly space needed in the clean room to a minimum. The front and the furnace interior in the clean room are designed for easy cleaning. With this configuration even the highest clean room classes can be achieved.



Sluice Furnace between Grey Room and Clean Room

Logistics between clean room and grey room can often be easily sorted out. Lock furnaces with one door in the grey room and the other door in the clean room are the perfect choice for these applications. The inner chamber as well as the furnace front in the clean room will be especially designed for lowest particle contamination.

Please contact us if you are looking for a heat treatment solution under clean room conditions. We would be pleased to quote for the oven or furnace model that meets best your requirements.

High-temperature furnace with loading from the clean room; switchgear and furnace installed in grey room



Hot-wall retort furnace NRA 1700/06 with charging frame for installation in grey room with charging door in clean room



Forced convection chamber furnace NAC 250/45 with clean room specs

Ovens, also with Safety Technology According to EN 1539 Electrically Heated



Oven TR 60 with adjustable fan speed



Oven TR 240



Electrical rotating device as additional equipment see page 13



Extricable metal grids to load the oven in different layers

With their maximum working temperature of up to 300 °C and air circulation, the ovens achieve a perfect temperature uniformity which is much better than in ovens of most competitors. They can be used for various applications such as e.g. drying, sterilizing or warm storing. Ample warehousing of standard models provides for short delivery times.

- Tmax 300 °C
- Working temperature range: + 5 °C above room temperature up to 300 °C
- Ovens TR 60 - TR 240 designed as tabletop models
- Ovens TR 450 and TR 1050 designed as floor standing models
- Horizontal, forced convection results in temperature uniformity better than +/- 5 °C see page 71
- Stainless steel chamber, alloy 304 (AISI)/(DIN material no. 1.4301), rust-resistant and easy to clean
- Large handle to open and close the door
- Charging in multiple layers possible using removeable grids (number of removeable grids included, see table to the right)
- Large, wide-opening swing door, hinged on the right with quick release for models TR 60 - TR 450
- Double swing door with quick release for TR 1050
- TR 1050 equipped transport rollers
- Infinitely adjustable exhaust at the rear wall with operation from the front
- PID microprocessor control with self-diagnosis system
- Solid state relays provide for lownoise operation
- Defined application within the constraints of the operating instructions
- NTLog Basic for Nabertherm controller: recording of process data with USB-flash drive
- Controls description see page 72

Additional equipment

- Over-temperature limiter with adjustable cutout temperature for thermal protection class 2 in accordance with EN 60519-2 as temperature limiter to protect the oven and load
- Infinitely adjustable fan speed of the air circulation fan



Oven TR 450



Oven TR 1050 with double door

- Window for charge observing
- Further removable grids with rails
- Side inlet
- Stainless steel collecting pan to protect the furnace chamber
- Door hinges left
- Reinforced bottom plate
- Safety Technology according to EN 1539 for charges (TR .. LS) containing liquid solvents up to model TR 240 LS, achievable temperature uniformity +/- 8 °C see page 71
- Transport costors for model TR 450
- Various modifications available for individual needs
- Upgrading available to meet the quality requirements of AMS 2750 E or FDA
- Process control and documentation via VCD software package for monitoring, documentation and control see page 75



Oven TR 60 with observation window and rotating device with selectable speed and door lock

Model	Tmax °C	Inner dimensions in mm			Volume in l	Outer dimensions in mm			Heating power in kW ²	Electrical connection*	Weight in kg	Grids included	Grids max.	Max. total load ¹
		w	d	h		W	D	H						
TR 60	300	450	390	350	60	700	610	710	3	1-phase	90	1	4	120
TR 60 LS	260	450	360	350	57	700	680	690	6	3-phase	92	1	4	120
TR 120	300	650	390	500	120	900	610	860	3	1-phase	120	2	7	150
TR 120 LS	260	650	360	500	117	900	680	840	6	3-phase	122	2	7	150
TR 240	300	750	550	600	240	1000	780	970	3	1-phase	165	2	8	150
TR 240 LS	260	750	530	600	235	1000	850	940	6	3-phase	167	2	8	150
TR 450	300	750	550	1100	450	1000	780	1470	6	3-phase	235	3	15	180
TR 1050	300	1200	670	1400	1050	1470	940	1920	9	3-phase	450	4	14	250

¹Max load per layer 30 kg

²Please see page 73 for more information about supply voltage

³If EN 1539 is ordered power rating will increase



Front made of textured stainless steel

Forced Convection Chamber Furnaces Electrically Heated



Forced convection chamber furnace NA 120/45



Forced convection chamber furnace NA 250/45



Forced convection chamber furnace
N 15/65HA as table-top model

The very good temperature uniformity of these forced convection chamber furnace with air circulation provides for ideal process conditions for annealing, curing, solution annealing, artificial ageing, preheating, or soft annealing and brazing. The forced convection chamber furnaces are equipped with a suitable annealing box for soft annealing of copper or tempering of titanium, and also for annealing of steel under non-flammable protective or reaction gases. The modular forced convection chamber furnace design allows for adaptation to specific process requirements with appropriate accessories.

- Tmax 450 °C, 650 °C, or 850 °C
- Stainless steel air-baffles in the furnace for optimum air circulation
- Swing door hinged on the right side
- Base frame included in the delivery, N 15/65 HA designed as table-top model
- Horizontal air circulation
- Temperature uniformity up to +/- 4 °C according to DIN 17052-1 (model N 15/65 HA up to +/- 7 °C) see page 71
- Optimum air distribution enabled by high flow speeds
- One frame sheet and rails for two additional trays included in the scope of delivery (N 15/65 HA without frame sheet)
- Defined application within the constraints of the operating instructions
- NTLog Basic for Nabertherm controller: recording of process data with USB-flash drive
- Controls description see page 68

Additional equipment (not for model N 15/65HA)

- Optimization of the temperature uniformity up to +/- 3 °C according to DIN 17052-1 see page 71
- Air inlet and exhaust air flaps when used for drying
- Controlled cooling with fan
- Manual lift door (up to model N(A) 120/.. (HA))
- Pneumatic lift door
- Air circulation with speed control, recommendable for processes with light or sensitive charge
- Additional frame sheet
- Roller conveyor in furnace chamber for heavy charges



Roller conveyor in forced convection
furnace N 250/85HA



Forced convection chamber furnace NA 500/65



Forced convection chamber furnace N 250/85HA with quenching bath

- Annealing boxes
- Feed and charging aids
- Safety technology according to EN 1539 (NFPA 86) (models NA .. LS) for charges containing solvents
- Inlets, measuring frames and thermocouples for TUS measurements charge or comparative measurements
- Charge control
- Process control and documentation via VCD software package or Nabertherm Control Center (NCC) for monitoring, documentation and control see page 72

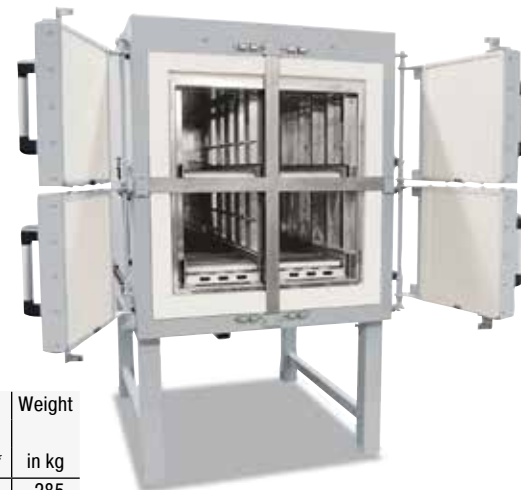

Forced convection chamber furnace NA 500/S with four compartments, each with roller conveyor and individual door

Model	Tmax °C	Inner dimensions in mm			Volume in l	Outer dimensions in mm			Heating power in kW ³ NA/NA .. LS	Electrical connection*	Weight in kg
		w	d	h		W	D	H			
NA 30/45(LS)	450	290	420	260	30	1040	1290	1385	3.0 / 9.0	1(3)-phase	285
NA 60/45(LS)	450	350	500	350	60	1100	1370	1475	6.0 / 12.0	3-phase	350
NA 120/45(LS)	450	450	600	450	120	1250	1550	1550	9.0 / 18.0	3-phase	460
NA 250/45(LS)	450	600	750	600	250	1350	1650	1725	12.0 / 24.0	3-phase	590
NA 500/45(LS)	450	750	1000	750	500	1550	1900	1820	18.0 / 24.0	3-phase	750
NA 675/45(LS)	450	750	1200	750	675	1550	2100	1820	24.0 / 30.0	3-phase	900
N 15/65 HA ¹	650	295	340	170	15	470	845	460	2.4	1-phase	55
NA 30/65	650	290	420	260	30	870	1290	1385	5.0	3-phase ²	285
NA 60/65	650	350	500	350	60	910	1390	1475	9.0	3-phase	350
NA 120/65	650	450	600	450	120	990	1470	1550	12.0	3-phase	460
NA 250/65	650	600	750	600	250	1170	1650	1680	20.0	3-phase	590
NA 500/65	650	750	1000	750	500	1290	1890	1825	27.0	3-phase	750
NA 675/65	650	750	1200	750	675	1290	2100	1825	27.0	3-phase	900
N 30/85 HA	850	290	420	260	30	607 + 255	1175	1315	5.5	3-phase ²	195
N 60/85 HA	850	350	500	350	60	667 + 255	1250	1400	9.0	3-phase	240
N 120/85 HA	850	450	600	450	120	767 + 255	1350	1500	13.0	3-phase	310
N 250/85 HA	850	600	750	600	250	1002 + 255	1636	1860	20.0	3-phase	610
N 500/85 HA	850	750	1000	750	500	1152 + 255	1886	2010	30.0	3-phase	1030
N 675/85 HA	850	750	1200	750	675	1152 + 255	2100	2010	30.0	3-phase	1350

¹Table-top model see page 14

²Heating only between two phases

³Please see page 73 for more information about supply voltage

³Depending on furnace design connected load might be higher

Bogie Hearth Furnaces with Wire Heating up to 1400 °C



Bogie hearth furnace W 1500/H



Bogie hearth furnace W 2060/S without bogie heating for preheating fusion molds

When cooling, decorating, glazing or sintering special glass during production, bogie hearth furnaces offer numerous advantages. Due to their very good temperature uniformity, these models are perfectly suited for burning in a separation layer of silicon nitride in crucibles for the solar industry. The bogie can be charged outside the furnace. Several shuttles can be used, so that one shuttle can be charged while the other shuttle is in the furnace.

- Tmax 1280 °C, 1340 °C or 1400 °C
- Dual shell housing with rear ventilation, provides for low shell temperatures
- Swing door hinged on the right side
- Heating from five sides (four sides and bogie) provides for an optimum temperature uniformity
- Bogie heating receives power via blade contacts when driven in
- Heating elements mounted on support tubes provide for free radiation and long service life
- Bottom heating protected by SiC tiles on the bogie providing level stacking surface
- Multi-layer insulation consisting of lightweight refractory bricks backed by microporous silica insulation
- Self-supporting and long-life ceiling construction with bricks laid in arched construction, for models up to 1340 °C
- Roof made of high-quality fiber material for models with Tmax 1400 °C
- Freely moveable bogie with rubber wheels up to model W 3300
- Adjustable air inlet damper
- Manual exhaust air flap on the furnace roof
- Over-temperature limiter with adjustable cutout temperature for thermal protection class 2 in accordance with EN 60519-2 as temperature limiter to protect the furnace and load
- Defined application within the constraints of the operating instructions
- NTLog Basic for Nabertherm controller: recording of process data with USB-flash drive
- Controls description see page 72



Bogie hearth furnace for tempering quartz rods



Bogie hearth furnace W 2200/14 DB200 with debinding package and catalytical post combustion



Bogie hearth furnace W 8250/S for tempering quartz glass

Additional equipment

- Fiber insulation also in combination with meander shaped heating for short heating times
- Bogies with flanged wheels running on rails for easy and precise movement of high loads or complex kiln furniture
- Electric chain-driven bogie in combination with rail operation for smooth movement of heavy loads
- Bogie running on steel wheels with gear rack drive, no rails in front of the furnace necessary
- Different possibilities for an extension to a bogie hearth furnace system:
 - Additional bogies
 - Bogie transfer system with parking rails to exchange bogies running on rails or to connect multiples furnaces
 - Motor-driven bogies and cross-traversal system
 - Fully automatic control of the bogie exchange
- Electro-hydraulic lift door
- Kiln furniture
- Motor-driven exhaust air flap
- Uncontrolled or controlled cooling system with frequency-controlled cooling fan and motor-driven exhaust air flap
- Multi-zone control adapted to the particular furnace provides model for optimal the temperature uniformity
- IDB design with gas supply system and safety technology for debinding in non-flammable protective gases
- Commissioning of the furnace with test firing and temperature uniformity measurement (also with load) for the purpose of process optimization
- Thermal or catalytic exhaust cleaning systems
- Process control and documentation via VCD software package or Nabertherm Control Center (NCC) for monitoring, documentation and control see page 72



Bogie hearth furnace W 7500 with bogie, separated in three parts

Bogie Hearth Furnaces with Wire Heating up to 1400 °C



Combi furnace system consisting of two bogie hearth furnaces W 5000/H and two additional bogies incl. bogie transfer system and incl. necessary park rails

Model	Tmax °C	Inner dimensions in mm			Volume in l	Outer dimensions in mm			Heating power in kW ¹	Electrical connection*	Weight in kg
		w	d	h		W	D	H			
W 1000	1280	800	1600	800	1000	1470	2410	1915	57	3-phase	3000
W 1500	1280	900	1900	900	1500	1570	2710	2030	75	3-phase	3500
W 2200	1280	1000	2200	1000	2200	1670	3010	2140	110	3-phase	4500
W 3300	1280	1000	2800	1200	3300	1670	3610	2355	140	3-phase	5300
W 5000	1280	1000	3600	1400	5000	1670	4410	2555	185	3-phase	7300
W 7500	1280	1000	5400	1400	7500	1670	6210	2555	235	3-phase	10300
W 10000	1280	1000	7100	1400	10000	1670	7910	2555	300	3-phase	12500
W 1000/H	1340	800	1600	800	1000	1470	2410	1915	75	3-phase	3500
W 1500/H	1340	900	1900	900	1500	1570	2710	2030	110	3-phase	4000
W 2200/H	1340	1000	2200	1000	2200	1670	3010	2140	140	3-phase	5000
W 3300/H	1340	1000	2800	1200	3300	1670	3610	2355	185	3-phase	6000
W 5000/H	1340	1000	3600	1400	5000	1670	4410	2555	235	3-phase	8000
W 7500/H	1340	1000	5400	1400	7500	1670	6210	2555	370	3-phase	11300
W 10000/H	1340	1000	7100	1400	10000	1670	7910	2555	440	3-phase	13800
W 1000/14	1400	800	1600	800	1000	1470	2410	1915	75	3-phase	3300
W 1500/14	1400	900	1900	900	1500	1570	2710	2030	110	3-phase	3800
W 2200/14	1400	1000	2200	1000	2200	1670	3010	2140	140	3-phase	4800
W 3300/14	1400	1000	2800	1200	3300	1670	3610	2355	185	3-phase	5700
W 5000/14	1400	1000	3600	1400	5000	1670	4410	2555	235	3-phase	7700
W 7500/14	1400	1000	5400	1400	7500	1670	6210	2555	370	3-phase	10900
W 10000/14	1400	1000	7100	1400	10000	1670	7910	2555	440	3-phase	13300

¹Depending on furnace design connected load might be higher

*Please see page 73 for more information about supply voltage



Bogie hearth furnace in IDB-version with gas box for debinding and sintering under non-flammable protective or reaction gases

High-Temperature Bogie Hearth Furnaces with SiC Rod Heating up to 1550 °C



High-temperature bogie hearth furnace WHTC 3300/15



High-temperature bogie hearth furnace WHTC 4000/15 with bogie on rails and fan cooling

Bogie hearth furnaces equipped with SiC rod heating can be used for the production of technical ceramics, especially for sintering at working temperatures up to 1550 °C. The bogie hearth furnaces from WHTC product line with especially robust design can hold heavy charges including kiln furniture. The furnace chamber is equipped with a high-quality insulation made of high-temperature fiber blocks. The bogie insulation is structured in multi-layer lightweight refractory bricks on the heating chamber side.

The furnace is heated along both sides by vertically installed SiC heating rods. This heating technology permits processes requiring working temperatures above 1350 °C which cannot be achieved with wire heating elements. The SiC rods are controlled by thyristor controller which counteracts the aging of the heating elements by means of automatic power compensation.



SiC rod elements on both sides of the bogie hearth furnace

- Tmax 1550 °C
- Dual shell housing with rear ventilation, provides for low shell temperatures
- Swing door hinged on the right side
- Heating from both sides via vertically mounted SiC rods
- Thyristor controllers with automatic output compensation counteract the aging of SiC rods
- Multi-layer insulation with high-quality fiber modules on the heating chamber side
- Bogie for heavy loads lined with lightweight refractory bricks
- Bogie hand driven on rubber tires
- Motor-driven exhaust air flap on the furnace roof
- Over-temperature limiter with adjustable cutout temperature for thermal protection class 2 in accordance with EN 60519-2 as temperature limiter to protect the furnace and load
- Defined application within the constraints of the operating instructions
- NTLog Basic for Nabertherm controller: recording of process data with USB-flash drive

Additional equipment

- Exhaust air and exhaust gas piping
- Thermal or catalytic exhaust cleaning systems
- Process control and documentation via VCD software package or Nabertherm Control Center (NCC) for monitoring, documentation and control see page 72



Design with two doors and two bogies, on rails, allows for rapid bogie changes

Chamber Furnaces with Wire Heating up to 1400 °C



Chamber furnace N 1000

These high-quality chamber furnaces for firing, sintering and tempering have qualified themselves with the reliability for many years in daily use. Thanks to their five-side heating, the furnaces provide for a very good temperature uniformity. A wide range of additional equipment perfectly adapt these chamber furnaces to the process requirements.

- Tmax 900 °C, 1300 °C, 1340 °C or 1400 °C
- Dual shell housing, galvanized steel sheets
- Five-side heating provide for good temperature uniformity
- Heating elements on support tubes provide for free heat radiation and long service life
- Controller mounted on furnace door and removable for comfortable operation
- Air outlet in the ceiling, motor driven exhaust air flap for models from N 440
- Smoothly adjustable and easy-to-operate air inlet flap or sliding damper
- Self-supporting and long-life ceiling construction, with bricks laid in arched construction
- Special door lock for easy handling
- Multi-layer insulation consisting of lightweight refractory bricks and backed by special fiber insulation
- Models up to N 300/.. with removable stand
- Protection of bottom heating and flat stacking surface provided by embedded SiC plate in the floor
- Defined application within the constraints of the operating instructions

Chamber furnace N 4550/S



- NTLog Basic for Nabertherm controller: recording of process data with USB-flash drive
- Controls description see page 72

Additional equipment

- Motor driven exhaust air flap for models N 100 - N 300/..
- Fan system for faster cooling with manual or automatic control
- Protective gas connection for purging the furnace with non-flammable protective or reaction gases

Chamber furnaces N 200/14 for sintering semiconductors

- Manual or automatic gas supply systems
- Fiber insulation for shorter cycle times, especially cooling periods
- Multi-zone control for optimal temperature uniformity in the work space
- Over-temperature limiter with adjustable cutout temperature for thermal protection class 2 in accordance with EN 60519-2 as temperature limiter to protect the furnace and load
- Process control and documentation via VCD software package or Nabertherm Control Center (NCC) for monitoring, documentation and control see page 72



Chamber furnace N 500/GS

Model	Tmax °C	Inner dimensions in mm			Volume in l	Outer dimensions in mm			Heating power in kW ¹	Electrical connection*	Weight in kg
		w	d	h		W	D	H			
N 100/G	900	400	530	460	100	720	1130	1440	7	3-phase	275
N 150/G	900	450	530	590	150	770	1130	1570	9	3-phase	320
N 200/G	900	500	530	720	200	790	1130	1760	11	3-phase	375
N 200/GS	900	400	1000	500	200	795	1710	1605	16	3-phase	300
N 250/GS	900	500	1000	500	250	895	1710	1605	18	3-phase	370
N 300/G	900	550	700	780	300	870	1300	1760	15	3-phase	450
N 360/GS	900	600	1000	600	360	995	1710	1705	20	3-phase	500
N 440/G	900	600	750	1000	450	1000	1400	1830	20	3-phase	780
N 500/GS	900	600	1400	600	500	995	2110	1705	22	3-phase	1000
N 660/G	900	600	1100	1000	660	1000	1750	1830	26	3-phase	950
N 1000/G	900	800	1000	1250	1000	1390	1760	2000	40	3-phase	1680
N 1500/G	900	900	1200	1400	1500	1490	1960	2150	57	3-phase	2300
N 2200/G	900	1000	1400	1600	2200	1590	2160	2350	75	3-phase	2800
N 100	1300	400	530	460	100	720	1130	1440	9	3-phase	275
N 150	1300	450	530	590	150	770	1130	1570	11	3-phase	320
N 200	1300	470	530	780	200	790	1130	1760	15	3-phase	375
N 200/S	1300	400	1000	500	200	795	1710	1605	18	3-phase	300
N 250/S	1300	500	1000	500	250	895	1710	1605	20	3-phase	370
N 300	1300	550	700	780	300	870	1300	1760	20	3-phase	450
N 360/S	1300	600	1000	600	360	995	1710	1705	22	3-phase	500
N 440	1300	600	750	1000	450	1000	1400	1830	30	3-phase	780
N 500/S	1300	600	1400	600	500	995	2110	1705	24	3-phase	370
N 660	1300	600	1100	1000	660	1000	1750	1830	40	3-phase	950
N 1000	1300	800	1000	1250	1000	1390	1760	2000	57	3-phase	1800
N 1500	1300	900	1200	1400	1500	1490	1960	2150	75	3-phase	2500
N 2200	1300	1000	1400	1600	2200	1590	2160	2350	110	3-phase	3100
N 100/H	1340	400	530	460	100	760	1150	1440	11	3-phase	325
N 150/H	1340	430	530	620	150	790	1150	1600	15	3-phase	380
N 200/H	1340	500	530	720	200	860	1150	1700	20	3-phase	430
N 300/H	1340	550	700	780	300	910	1320	1760	27	3-phase	550
N 440/H	1340	600	750	1000	450	1000	1400	1830	40	3-phase	880
N 660/H	1340	600	1100	1000	660	1000	1750	1830	52	3-phase	1080
N 1000/H	1340	800	1000	1250	1000	1390	1760	2000	75	3-phase	2320
N 1500/H	1340	900	1200	1400	1500	1490	1960	2150	110	3-phase	2700
N 2200/H	1340	1000	1400	1600	2200	1590	2160	2350	140	3-phase	3600
N 100/14	1400	400	530	460	100	760	1150	1440	15	3-phase	325
N 150/14	1400	430	530	620	150	790	1150	1600	20	3-phase	380
N 200/14	1400	500	530	720	200	860	1150	1700	22	3-phase	430
N 300/14	1400	550	700	780	300	910	1320	1760	30	3-phase	550
N 440/14	1400	600	750	1000	450	1000	1400	1820	40	3-phase	1320
N 660/14	1400	600	1100	1000	660	1000	1750	1820	57	3-phase	1560
N 1000/14	1400	800	1000	1250	1000	1390	1760	2000	75	3-phase	2500
N 1500/14	1400	900	1200	1400	1500	1490	1960	2150	110	3-phase	3000
N 2200/14	1400	1000	1400	1600	2200	1590	2160	2350	140	3-phase	3900



Chamber furnace with fiber insulation for shorter cycle times



Charging trolley for chamber furnace N 2200

¹Depending on furnace design connected load might be higher

*Please see page 73 for more information about supply voltage

Chamber Furnaces with Brick Insulation or Fiber Insulation



Chamber furnace LH 15/12 with brick insulation



Chamber furnace LH 30/14

The chamber furnaces LH 15/12 - LF 120/14 have been trusted for many years as professional chamber furnaces for the laboratory. These furnaces are available with either a robust insulation of light refractory bricks (LH models) or with a combination insulation of refractory bricks in the corners and low heat storage, quickly cooling fiber material (LF models). With a wide variety of optional equipment, these chamber furnaces can be optimally adapted to your processes.

- Tmax 1200 °C, 1300 °C, or 1400 °C
- Dual shell housing with rear ventilation, provides for low shell temperatures
- Five-sided heating for very good temperature uniformity
- Heating elements on support tubes ensure free heat radiation and a long service life
- Controller mounted on furnace door and removable for comfortable operation
- Protection of bottom heating and flat stacking surface provided by embedded SiC plate in the floor
- LH models: multi-layered, fiber-free insulation of light refractory bricks and special backup insulation
- LF models: high-quality non-classified fiber insulation with corner bricks for shorter heating and cooling times
- Door with brick-on-brick seal, hand fitted
- Short heating times due to high installed power
- Motor driven exhaust air flap
- Self-supporting arch for high stability and greatest possible protection against dust
- Quick lock on door
- Freely adjustable air slide intake in furnace floor
- Stand included
- Defined application within the constraints of the operating instructions
- NTLog Basic for Nabertherm controller: recording of process data with USB-flash drive
- Controls description see page 72

Additional equipment

- Parallel swinging door, pivots away from operator, for opening when hot
- Lift door with electro-mechanic linear drive
- Separate wall-mounting or floor standing cabinet for switchgear
- Cooling fan for shorter cycle times



Chamber furnace LH 60/12 with manual lift door



Chamber furnace LH 60/13 DB50 for debinding in air



Chamber furnace LH 120/12

- Protective gas connection for purging the furnace with non-flammable protective or reaction gases
- Manual or automatic gas supply system
- Scale to measure weight reduction during annealing
- Debinding packages with safety concept up to 60 liters
- Process control and documentation via VCD software package or Nabertherm Control Center (NCC) for monitoring, documentation and control see page 72



Cooling fan in combination with motor-driven exhaust air flap to reduce cooling time

Model	Tmax °C	Inner dimensions in mm			Volume in l	Outer dimensions in mm			Heating power in kW ²	Electrical connection*	Weight in kg
		w	d	h		W	D	H			
LH 15/12	1200	250	250	250	15	680	860	1230	5.0	3-phase ¹	170
LH 30/12	1200	320	320	320	30	710	930	1290	7.0	3-phase ¹	200
LH 60/12	1200	400	400	400	60	790	1080	1370	8.0	3-phase	300
LH 120/12	1200	500	500	500	120	890	1180	1470	12.0	3-phase	410
LH 216/12	1200	600	600	600	216	990	1280	1590	20.0	3-phase	450
LH 15/13	1300	250	250	250	15	680	860	1230	7.0	3-phase ¹	170
LH 30/13	1300	320	320	320	30	710	930	1290	8.0	3-phase ¹	200
LH 60/13	1300	400	400	400	60	790	1080	1370	11.0	3-phase	300
LH 120/13	1300	500	500	500	120	890	1180	1470	15.0	3-phase	410
LH 216/13	1300	600	600	600	216	990	1280	1590	22.0	3-phase	460
LH 15/14	1400	250	250	250	15	680	860	1230	8.0	3-phase ¹	170
LH 30/14	1400	320	320	320	30	710	930	1290	10.0	3-phase ¹	200
LH 60/14	1400	400	400	400	60	790	1080	1370	12.0	3-phase	300
LH 120/14	1400	500	500	500	120	890	1180	1470	18.0	3-phase	410
LH 216/14	1400	600	600	600	216	990	1280	1590	26.0	3-phase	470
LF 15/13	1300	250	250	250	15	680	860	1230	7.0	3-phase ¹	150
LF 30/13	1300	320	320	320	30	710	930	1290	8.0	3-phase ¹	180
LF 60/13	1300	400	400	400	60	790	1080	1370	11.0	3-phase	270
LF 120/13	1300	500	500	500	120	890	1180	1470	15.0	3-phase	370
LF 15/14	1400	250	250	250	15	680	860	1230	8.0	3-phase ¹	150
LF 30/14	1400	320	320	320	30	710	930	1290	10.0	3-phase ¹	180
LF 60/14	1400	400	400	400	60	790	1080	1370	12.0	3-phase	270
LF 120/14	1400	500	500	500	120	890	1180	1470	18.0	3-phase	370

¹Heating only between two phases

*Please see page 73 for more information about supply voltage

²Depending on furnace design connected load might be higher



Parallel swinging door for opening when hot



Gas supply system

Top Hat Furnaces or Bottom Loading Furnaces with Wire Heating up to 1400 °C



Bottom loading furnace H 1000/LB



Top hat furnace H 1600/14 DB 200

These top hat furnaces or bottom loading furnaces were specially developed for cooling complex structures or when the process requires the treatment of warm glass, e.g., the welding process in glass apparatus manufacturing. The wide-opening electro-hydraulically driven top hat allows furnace opening even at high temperatures and provides easy access from 3 sides. Depending on process conditions, a top hat or bottom loading version is advisable. The system can be expanded to include one or more changeable tables, either manually or motor driven. Further additional equipment like a multi-zone control to optimize the temperature uniformity or controlled cooling systems for shorter processes provide for customized solution with respect to the process requirements.

- Tmax 1280 °C
- Dual shell housing with rear ventilation for low shell temperatures
- Top hat furnaces: electrohydraulically driven top hat with fixed table
- Bottom loading furnaces: driven table and fixed top hat
- Five-sided heating from all four sides and from the table provides for a temperature uniformity up to +/- 10 °C according to DIN 17052-1 see page 71
- Heating elements mounted on support tubes provide for free radiation and long service life of the heating wire
- Bottom heating protected by SiC tiles which provide for a level stacking surface
- Multi-layer insulation consisting of lightweight refractory bricks backed by special insulation
- Long-life ceiling design with fiber insulation
- Manual exhaust air flap on the furnace roof
- Over-temperature limiter with adjustable cutout temperature for thermal protection class 2 in accordance with EN 60519-2 as temperature limiter to protect the furnace and load
- Defined application within the constraints of the operating instructions



Top hat furnace H 240/S. Table accessible from four sides for welding quartz glass constructions by vertical and horizontal moveable top hat



- NTLog Basic for Nabertherm controller: recording of process data with USB-flash drive
- Controls description see page 72

Top hat furnace H 500 DB200 with catalytic post combustion, automatic table changing system and safety scanners to protect the danger zone

Additional equipment

- Tmax to 1400 °C
- Motor driven exhaust air flap, switchable via the program
- Uncontrolled or controlled cooling system with frequency-controlled cooling fan and motor-driven exhaust air flap
- Protective gas connection for purging the furnace with non-flammable protective or reaction gases
- Manual or automatic gas supply systems
- Multi-zone control adapted to the particular furnace provides model for optimal the temperature uniformity
- Commissioning of the furnace with test firing and temperature uniformity measurement (also with load) for the purpose of process optimization
- Additional tables, table changing system, also motor-driven
- Exhaust air and exhaust gas piping
- Thermal or catalytic exhaust cleaning systems
- Process control and documentation via VCD software package or Nabertherm Control Center (NCC) for monitoring, documentation and control see page 72



Top hat furnace system H 245/LTS with cooling station and table changing system

Model	Tmax °C	Inner dimensions in mm			Volume in l	Outer dimensions in mm			Heating power in kW ¹	Electrical connection*	Weight in kg
		w	d	h		W	D	H			
H 125/LB, LT	1280	800	400	400	125	1550	1500	2200	12	3-phase	1250
H 250/LB, LT	1280	1000	500	500	250	1530	1700	2300	18	3-phase	1400
H 500/LB, LT	1280	1200	600	600	500	2020	1800	2500	36	3-phase	1800
H 1000/LB, LT	1280	1600	800	800	1000	2200	2000	2900	48	3-phase	2800
H 1350/LB, LT	1280	2800	620	780	1360	3750	2050	3050	75	3-phase	3500
H 3000/LB, LT	1280	3000	1000	1000	3000	4000	2100	3200	140	3-phase	6200

¹Depending on furnace design connected load might be higher

*Please see page 73 for more information about supply voltage



Kiln furniture for small ceramics components

Top Hat Furnaces with SiC Rod Heating



Top hat furnace HC 1275 with moveable table



Top hat furnace HC 1500



Manually or electrically driven table as option

For temperatures beyond 1350 °C we recommend top hat furnaces with SiC rod heating. The top hat construction with 4-sides heating provides for exceptional temperature uniformity.

- Tmax of 1400 °C, 1450 °C or 1500 °C
- SiC rod heating on 4 sides of the furnace top hat for short cycle times and high temperature uniformity
- High electrical connected load for short cycle times
- Top hat insulation made from fiber materials provides for short cycle time and low energy consumption
- Table built from lightweight refractory bricks allows for heavy loads and level stacking surface
- Electro-hydraulic driven top hat for vibration-free opening and closing of furnace top hat
- Thyristor powered heating
- Defined application within the constraints of the operating instructions
- NTLog Basic for Nabertherm controller: recording of process data with USB-flash drive
- Controls description see page 72

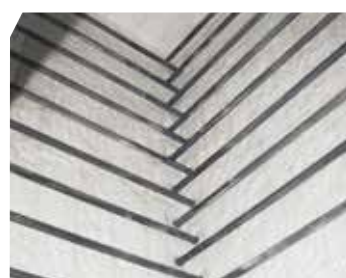

Heating from 4 sides with SiC rods

Model	Tmax °C	Inner dimensions in mm			Volume in l	Outer dimensions in mm			Heating power in kW ¹	Electrical connection*	Weight in kg
		w	d	h		W	D	H			
HC 665	1400	1100	550	1100	665	2350	2050	4000	186	3-phase	3000
HC 1275	1400	850	1000	1500	1275	2100	2500	4400	180	3-phase	4100
HC 1440	1400	840	2400	840	1690	2100	3900	3560	400	3-phase	4700
HC 1500	1400	1000	1000	1500	1500	2250	2500	4400	190	3-phase	5300
HC 1280	1450	800	1600	1000	1280	2050	3100	3900	151	3-phase	4200
HC 700	1500	800	800	1100	700	2050	2300	4000	100	3-phase	3100
HC 1400	1500	800	1600	1100	1400	2050	3100	4000	151	3-phase	4500

¹Depending on furnace design connected load might be higher

*Please see page 73 for more information about supply voltage

Pit-Type and Top-Loading Furnaces with or without Air Circulation Electrically Heated or Gas-Fired

Our top-loading furnaces are perfectly suited for firing, sintering or tempering of long, heavy products. The furnace is usually charged with a factory crane. Due to their high-performance air circulation system, the furnaces provide for excellent temperature uniformity up to a maximum temperature of 850 °C. The top-loading furnaces for the temperature range up to 1280 °C provide for very good temperature uniformity due to their five-side heating. Alternatively, these furnaces can also be provided with gas-fired. Customized dimensions are designed and produced to accommodate the size and weight of the components to be treated.



- Tmax 260 °C, 450 °C, 600 °C or 850 °C for furnaces with air circulation
- Tmax 900 °C or 1280 °C for furnaces with radiation heating
- Electrically heated or gas-fired
- Heating from both long sides for furnaces with air circulation
- Heating from all four sides and the floor with SiC plates in the floor as level stacking support for models to 900 °C or 1280 °C
- High-quality insulation, adapted to the specific maximum temperature
- Electrohydraulic opening system of the lid with two-hand operation
- Closable air supply vents in the lower area of the furnace chamber
- Closable exhaust air vents in the lid
- Over-temperature limiter with adjustable cutout temperature for thermal protection class 2 in accordance with EN 60519-2 as temperature limiter to protect the furnace and load
- Defined application within the constraints of the operating instructions

Top-loading furnace S 5120/GS1, furnace chamber divided in two sections, split cover



Furnace chamber S 5120/GS with receptacle for an insulating plate in order to divide the furnace chamber

Additional equipment

- Motor driven exhaust air flaps for faster cooling
- Controlled fan cooling with motor driven exhaust air flaps
- Multi-zone control of the heating provides for optimum temperature uniformity
- Furnace chamber can be divided in length for short workparts, partitions can be controlled separately
- Designed for Tmax 950 °C, fan blade driven indirectly via a belt to protect the air recirculation motor against overheating
- Process control and documentation via VCD software package or Nabertherm Control Center (NCC) for monitoring, documentation and control see page 72



Charge supports for long tubes in a top-loading forced convection furnace SAL 750/08



Top-loading furnace SAT 1512/85S



Pit-type furnace S 11988/S with rolling lid

High-Temperature Furnaces with Molybdenum Disilicide Heating Elements with Fiber Insulation up to 1800 °C



High-temperature furnace HT 16/18 with gas supply system



High-temperature furnace HT 160/17 DB200 with debinding package



Protection of heating elements against mechanical damage



Inner process hood with gas injection through the furnace bottom protects the furnace chamber against contamination and/or prevents chemical interaction between the charge and heating elements

The high-temperature furnaces HT 04/16 - HT 450/18 have proven reliability over many years in laboratory and production. Whether for quartz glass or glass ceramics, for sintering CIM components or for other processes up to a maximum temperature of 1800 °C, these furnaces afford the optimal solution for the sintering process.

High-temperature furnaces can either be insulated with fiber material or lightweight refractory bricks. Furnaces with fiber insulation achieve significantly shorter heating up times because of the low thermal mass. An insulation made of lightweight refractory bricks (see HFL models on page 32), on the other hand, has the advantage of better chemical stability.

These furnaces can also be tailored to specific processes by means of a wide range of additional equipment. The addition of a debinding package, for example, allows the use of these models as combi furnace for debinding and sintering in one process. Thermal or catalytic exhaust cleaning equipment rounds-off the system.

- Tmax 1600 °C, 1750 °C or 1800 °C
- Recommended working temperature 1750 °C (for models HT ../18), increased wear and tear must be expected in case of working at higher temperatures
- Dual shell housing with fan cooling for low shell temperatures
- Heating from both sides via molybdenum disilicide heating elements
- High-quality fiber insulation backed by special insulation
- Side insulation constructed with tongue and groove blocks provides for low heat loss to the outside
- Long-life roof insulation with special suspension
- Chain-guided parallel swivel door for defined opening and closing of the door
- Two-door design (front/back) for high-temperature furnaces > HT 276/..
- Labyrinth sealing ensures the least possible temperature loss in the door area
- Reinforced floor as protection for fiber insulation as standard from models HT 16/16 upwards
- Exhaust air opening in the furnace roof
- Heating elements switched via thyristors
- Over-temperature limiter with adjustable cutout temperature for thermal protection class 2 in accordance with EN 60519-2 as temperature limiter to protect the furnace and load
- Defined application within the constraints of the operating instructions



High-temperature furnace HT 160/18 DB200 with debinding package and pneumatically driven and parallel lift door



High-temperature furnace HT 64/17 DB100 with debinding package

- NTLog Basic for Nabertherm controller: recording of process data with USB-flash drive
- Controls description see page 28

Additional equipment

- Uncontrolled or controlled cooling system with frequency-controlled cooling fan and motor-driven exhaust air flap
- Furnace in DB design featuring fresh air preheating, exhaust gas ventilation and an extensive safety package for debinding and sintering in one process, i. e. without transferring the material from the debinding furnace to the sintering furnace
- Stainless steel exhaust gas hoods
- Commissioning of the furnace with test firing and temperature uniformity measurement (also with load) for the purpose of process optimization
- Temperature measurement with thermocouples, types B and type S with automatic pull-out device for precise control results in the low temperature range
- Protection grid in front of the heating elements to prevent mechanical damages see page 32
- Special heating elements for zirconia sintering provide for longer service life with respect to chemical interaction between charge and heating elements
- Protective gas connection for purging the furnace with non-flammable protective or reaction gases
- Manual or automatic gas supply system
- Inner process box to improve the gas tightness and to protect the furnace chamber against contamination
- Lift door
- Bottom insulation made of durable lightweight refractory bricks for heavy charge weights
- Motorized exhaust air flap, switchable via the program
- Exhaust air and exhaust gas piping
- Thermal or catalytic exhaust cleaning systems
- FID measurement for process optimization
- Process control and documentation via VCD software package or Nabertherm Control Center (NCC) for monitoring, documentation and control see page 72



Fresh air injection through perforated injection tubes with debinding package DB200



Display of pressure and volume flow with debinding package DB200

High-Temperature Furnaces with Molybdenum Disilicide Heating Elements with Fiber Insulation up to 1800 °C



High-temperature furnace HT 1000/17 with two movable door segments and fourside heating for sintering hanging ceramic tubes up to 1700 °C



Two-door design for high-temperature furnaces > HT 276/..



Gas supply system for non-flammable protective or reaction gases

Model	Tmax °C	Inner dimensions in mm			Volume in l	Outer dimensions in mm			Heating power in kW ²	Electrical connection*	Weight in kg
		w	d	h		W	D	H			
HT 04/16	1600	150	150	150	4	730	490	1400	5.2	3-phase ¹	150
HT 08/16	1600	150	300	150	8	730	640	1400	8.0	3-phase ¹	200
HT 16/16	1600	200	300	260	16	810	700	1500	12.0	3-phase ¹	270
HT 40/16	1600	300	350	350	40	1000	800	1620	12.0	3-phase	380
HT 64/16	1600	400	400	400	64	1130	900	1670	18.0	3-phase	550
HT 128/16	1600	400	800	400	128	1130	1290	1670	26.0	3-phase	750
HT 160/16	1600	500	550	550	160	1250	1050	1900	21.0	3-phase	800
HT 276/16	1600	500	1000	550	276	1300	1600	1900	36.0	3-phase	1100
HT 450/16	1600	500	1150	780	450	1350	1740	2120	64.0	3-phase	1500
HT 04/17	1750	150	150	150	4	730	490	1400	5.2	3-phase ¹	150
HT 08/17	1750	150	300	150	8	730	640	1400	8.0	3-phase ¹	200
HT 16/17	1750	200	300	260	16	810	700	1500	12.0	3-phase ¹	270
HT 40/17	1750	300	350	350	40	1000	800	1620	12.0	3-phase	380
HT 64/17	1750	400	400	400	64	1130	900	1670	18.0	3-phase	550
HT 128/17	1750	400	800	400	128	1130	1290	1670	26.0	3-phase	750
HT 160/17	1750	500	550	550	160	1250	1050	1900	21.0	3-phase	800
HT 276/17	1750	500	1000	550	276	1300	1600	1900	36.0	3-phase	1100
HT 450/17	1750	500	1150	780	450	1350	1740	2120	64.0	3-phase	1500
HT 04/18	1800	150	150	150	4	730	490	1400	5.2	3-phase ¹	150
HT 08/18	1800	150	300	150	8	730	640	1400	8.0	3-phase ¹	200
HT 16/18	1800	200	300	260	16	810	700	1500	12.0	3-phase ¹	270
HT 40/18	1800	300	350	350	40	1000	800	1620	12.0	3-phase	380
HT 64/18	1800	400	400	400	64	1130	900	1670	18.0	3-phase	550
HT 128/18	1800	400	800	400	128	1130	1290	1670	26.0	3-phase	750
HT 160/18	1800	500	550	550	160	1250	1050	1900	21.0	3-phase	800
HT 276/18	1800	500	1000	550	276	1300	1600	1900	42.0	3-phase	1100
HT 450/18	1800	500	1150	780	450	1350	1740	2120	64.0	3-phase	1500

¹Heating only between two phases

²Depending on furnace design connected load might be higher

*Please see page 73 for more information about supply voltage

High-Temperature Furnaces with SiC Rod Heating up to 1550 °C

The high-temperature furnaces HTC 16/16 - HTC 450/16 are heated by vertically hung SiC rods, which makes them especially suitable for sintering processes up to a maximum operating temperature of 1550 °C. For some processes, e.g. for sintering zirconia, the absence of interactivity between the charge and the SiC rods, these models are more suitable than the alternatives heated with molybdenum disilicide elements. The basic construction of these furnaces make them comparable with the already familiar models in the HT product line and they can be upgraded with the same additional equipment.

- Tmax 1550 °C
- Dual shell housing with fan cooling for low shell temperatures
- Heating from both sides via vertically mounted SiC rods
- High-quality fiber insulation backed by special insulation
- Side insulation constructed with tongue and groove blocks provides for low heat loss to the outside
- Long-life roof insulation with special suspension
- Chain-guided parallel swivel door for defined opening and closing of the door without destroying the insulation
- Two-door design (front/back) for high-temperature furnaces > HTC 276/..
- Labyrinth sealing ensures the least possible temperature loss in the door area
- Reinforced floor as protection for fiber insulation and to load heavy weights
- Exhaust air opening in the furnace roof
- Heating elements switched via SCR's
- Over-temperature limiter with adjustable cutout temperature for thermal protection class 2 in accordance with EN 60519-2 as temperature limiter to protect the furnace and load
- Defined application within the constraints of the operating instructions
- NTLog Basic for Nabertherm controller: recording of process data with USB-flash drive
- Controls description see page 72

Additional equipment like HT models see page 29



High-temperature furnace HTC 40/16



Vertically mounted SiC rods and optional perforated air inlet tubes of the debinding system

Model	Tmax °C	Inner dimensions in mm			Volume in l	Outer dimensions in mm			Heating power in kW ²	Electrical connection*	Weight in kg
		w	d	h		W	D	H			
HTC 16/16	1550	200	300	260	16	810	700	1500	12	3-phase ¹	270
HTC 40/16	1550	300	350	350	40	1000	800	1620	12	3-phase	380
HTC 64/16	1550	400	400	400	64	1130	900	1670	18	3-phase	550
HTC 128/16	1550	400	800	400	128	1130	1290	1670	26	3-phase	750
HTC 160/16	1550	500	550	550	160	1250	1050	1900	21	3-phase	800
HTC 276/16	1550	500	1000	550	276	1300	1600	1900	36	3-phase	1100
HTC 450/16	1550	500	1150	780	450	1350	1740	2120	64	3-phase	1500

¹Heating only between two phases

²Depending on furnace design connected load might be higher

*Please see page 73 for more information about supply voltage



Exhaust-air flap and charge thermocouple including a stand as additional equipment

High Temperature Furnaces with Molybdenum Disilicide Heating Elements with Refractory Brick Insulation up to 1700 °C



High-temperature furnace HFL 160/17



High-temperature furnace HFL 16/17



Protection grid in front of heating elements prevent against mechanical damages



Gas supply system for non-flammable protective or reaction gases



Front made of textured stainless steel

The high-temperature furnaces HFL 16/16 - HFL 160/17 are characterized by its lining with robust refractory insulation. Compared with the fiber-insulated models of the HT product line, these furnaces are recommended when high charge weights have to be sintered. In most cases lightweight refractory brick insulation is also significantly more resistant to gas emissions occurring during heat treatment.

Standard equipment like high-temperature furnaces HT, except:

- Tmax 1600 °C or 1700 °C
- Robust refractory brick insulation and special backing insulation
- Furnace floor made of lightweight refractory bricks accommodates high charge weights
- Defined application within the constraints of the operating instructions
- NTLog Basic for Nabertherm controller: recording of process data with USB-flash drive
- Controls description see page 72

Additional equipment like HT models see page 29

Model	Tmax °C	Inner dimensions in mm			Volume in l	Outer dimensions in mm			Heating power in kW ²	Electrical connection*	Weight in kg
		w	d	h		W	D	H			
HFL 16/16	1600	200	300	260	16	1000	890	1620	12	3-phase ¹	500
HFL 40/16	1600	300	350	350	40	1130	915	1890	12	3-phase	660
HFL 64/16	1600	400	400	400	64	1230	980	1940	18	3-phase	880
HFL 160/16	1600	500	550	550	160	1400	1250	2100	21	3-phase	1140
HFL 16/17	1700	200	300	260	16	1000	890	1620	12	3-phase ¹	530
HFL 40/17	1700	300	350	350	40	1130	915	1890	12	3-phase	690
HFL 64/17	1700	400	400	400	64	1230	980	1940	18	3-phase	920
HFL 160/17	1700	500	550	550	160	1400	1250	2100	21	3-phase	1190

¹Heating only between two phases

²Depending on furnace design connected load might be higher

*Please see page 73 for more information about supply voltage

Gas-Fired High-Temperature Furnaces up to 1600 °C

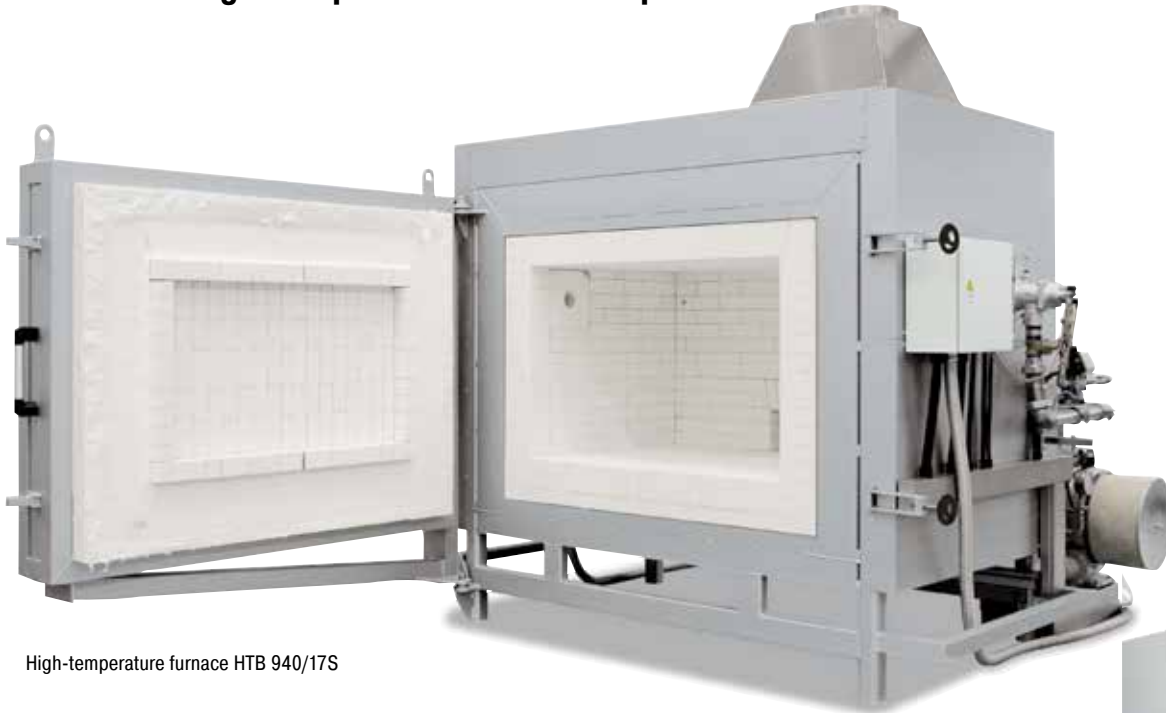

High-temperature furnace HTB 940/17S

The gas-fired high-temperature furnaces of the HTB product line are specially developed for applications requiring fast heating up ramps. Gas-fired high-temperature furnaces are preferred also if inflammable gases are produced in large amounts during the process. A large content of the gas emissions are already burned in the furnace chamber, so that downstream equipment like thermal and catalytic exhaust cleaners can accordingly be downsized. The furnaces are insulated with highly heat-resistant and long-life lightweight refractory brick insulation or fiber materials.

- Tmax 1600 °C
- Powerful, sturdy high-speed burners with pulse control and special flame guidance in the furnace chamber provide for good temperature uniformity
- Operation with natural gas, propane or liquified gas
- Fully automatic PLC control of the temperature, including monitoring of the burner function
- Gas fittings according to DVGW (German Technical and Scientific Association for Gas and Water) with flame monitoring and safety valve
- Reduction-resistant fiber insulation with low heat storage provides for short heating and cooling times
- Dual shell housing provides for low outside temperatures
- Exhaust hood with fittings for further discharge of the exhaust gases
- Defined application within the constraints of the operating instructions
- NTLog Basic for Nabertherm controller: recording of process data with USB-flash drive
- PLC control with touch panel as user interface see page 72

Additional equipment

- Automatic lambda control to set the furnace atmosphere
- Exhaust air and exhaust gas piping
- Recuperator burners
- Thermal or catalytic exhaust cleaning systems
- Process control and documentation via Nabertherm Control Center (NCC) for monitoring, documentation and control see page 72



Gas line for natural gas



High-temperature furnace HTB 645/17

Top Hat Furnaces or Bottom Loading Furnaces with Molybdenum Disilicide Heating Elements up to 1800 °C



Bottom loading furnace HT 166/17 LB



Bottom loading furnace HT 500/17 LB



Heat from all sides and between the stack to optimize temperature uniformity

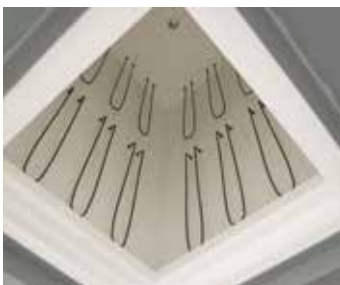

Heating elements arranged one above the other for tall structures

For charging complex settings we recommend top hat furnaces or bottom loading furnaces. Also small workparts can be conveniently loaded on different layers.

The basic furnace comes with one table. Depending on the technical requirements are equipped, a top hat furnace or a bottom loading furnace will be the choice.

The system can be expanded with one or more changeable tables, either manually or electrically driven. Other additional equipment, like controlled cooling systems to short process cycles or the addition of a debinding package for debinding and sintering in one process provide for tailored solution for individual needs.

- Tmax 1600 °C, 1750 °C or 1800 °C
- Dual shell housing with fan cooling provides for low shell temperatures
- Top hat furnaces: electrohydraulically driven top hat with fixed table
- Bottom loading furnaces: driven table and fixed top hat
- Gently running, low-vibration spindle drive or electrohydraulic drive for larger models
- Safe and tight closing of the furnace by means of labyrinth seal
- Heating from all four sides provides for good temperature uniformity
- High-quality fiber insulation backed by special insulation
- Side insulation constructed with tongue and groove blocks provides for low heat dissipation to the outside
- Long-life roof insulation with special suspension
- Furnace table with special bottom reinforcement to accommodate high charge weights
- Motor-driven exhaust air flap in the furnace roof, switchable at the program
- Heating elements switched via SCR's
- Over-temperature limiter with adjustable cutout temperature for thermal protection class 2 in accordance with EN 60519-2 as temperature limiter to protect the furnace and load
- Defined application within the constraints of the operating instructions
- NTLog Basic for Nabertherm controller: recording of process data with USB-flash drive
- Controls description see page 72

Additional equipment

- Uncontrolled or controlled cooling system with frequency-controlled cooling fan and motor-driven exhaust air flap
- Furnace in DB design featuring fresh air preheating, exhaust gas ventilation and an extensive safety package for debinding and sintering in one process, i. e. without transferring the material from the debinding furnace to the sintering furnace
- Stainless steel exhaust gas hoods
- Commissioning of the furnace with test firing and temperature uniformity measurement (also with load) for the purpose of process optimization
- Temperature measurement with thermocouples, types B and type S with automatic pull-out device for precise control results in the low temperature range
- Special heating elements for zirconia sintering provide for longer service life with respect to chemical interaction between charge and heating elements
- Heat from all sides and between the stack or with heating elements, positioned above each other to optimize temperature uniformity
- Protective gas connection for purging the furnace with non-flammable protective or reaction gases
- Manual or automatic gas supply systems
- Inner process box to improve the gas tightness and to protect the furnace chamber against contamination
- Bottom insulation made of durable lightweight refractory bricks for heavy charge weights
- Gas supply system in the furnace chamber with ceramic bell jar, protective gas inlet and outlet from below for better sealing when operating with protective gases and/or to prevent from chemical interactions between the load and the insulation or the heating elements
- Alternative table changing systems
- Exhaust air and exhaust gas piping
- Thermal or catalytic exhaust cleaning systems
- FID measurement for process optimization
- Process control and documentation via VCD software package or Nabertherm Control Center (NCC) for monitoring, documentation and control see page 72



Top hat furnace HT 276/18 LTS with two inner process hoods for sintering under non-flammable protective or reaction gases



Top hat furnace HT 276/17 LT with manual table changing system



Gas supply system for non-flammable protective or reaction gas



Measurement setup to determine the temperature uniformity in a high-temperature bottom loading furnace

Top Hat Furnaces or Bottom Loading Furnaces with Molybdenum Disilicide Heating Elements up to 1800 °C



High-temperature top hat furnace HT 2600/16 LT DB200 for production



Top hat furnace HT 750/18 LTS

Model	Tmax	Inner dimensions in mm			Volume in l	Outer dimensions in mm			Heating power in kW ¹	Electrical connection*	Weight in kg
	°C	w	d	h		W	D	H			
HT 64/16 LB, LT	1600	400	400	400	64	1100	1750	2400	36	3-phase	1100
HT 166/16 LB, LT	1600	550	550	550	166	1350	2060	2600	42	3-phase	1500
HT 276/16 LB, LT	1600	1000	500	550	276	1800	2100	2600	69	3-phase	1850
HT 400/16 LB, LT	1600	1200	600	550	400	1900	2200	2680	69	3-phase	2600
HT 500/16 LB, LT	1600	1550	600	550	500	2100	2200	2680	69	3-phase	2700
HT 1000/16 LB, LT	1600	1000	1000	1000	1000	1800	2900	3450	140	3-phase	3000
HT 1030/16 LB, LT	1600	2200	600	780	1030	2950	2500	3050	160	3-phase	3200
HT 64/17 LB, LT	1750	400	400	400	64	1100	1750	2400	36	3-phase	1100
HT 166/17 LB, LT	1750	550	550	550	166	1350	2060	2600	42	3-phase	1500
HT 276/17 LB, LT	1750	1000	500	550	276	1800	2100	2600	69	3-phase	1850
HT 400/17 LB, LT	1750	1200	600	550	400	1900	2200	2680	69	3-phase	2600
HT 500/17 LB, LT	1750	1550	600	550	500	2100	2200	2680	69	3-phase	2700
HT 1000/17 LB, LT	1750	1000	1000	1000	1000	1800	2900	3450	140	3-phase	3000
HT 1030/17 LB, LT	1750	2200	600	780	1030	2950	2500	3050	160	3-phase	3200
HT 64/18 LB, LT	1800	400	400	400	64	1100	1750	2400	36	3-phase	1100
HT 166/18 LB, LT	1800	550	550	550	166	1350	2060	2600	42	3-phase	1500
HT 276/18 LB, LT	1800	1000	500	550	276	1800	2100	2600	69	3-phase	1850
HT 400/18 LB, LT	1800	1200	600	550	400	1900	2200	2680	69	3-phase	2600
HT 500/18 LB, LT	1800	1550	600	550	500	2100	2200	2680	69	3-phase	2700
HT 1000/18 LB, LT	1800	1000	1000	1000	1000	1800	2900	3450	140	3-phase	3000
HT 1030/18 LB, LT	1800	2200	600	780	1030	2950	2500	3050	160	3-phase	3200

¹Depending on furnace design connected load might be higher

*Please see page 73 for more information about supply voltage



High-temperature furnace HT 273/17S with table by transportable fork lift



Production system consisting of a bogie hearth furnace for debinding and a high-temperature furnace for residual debinding and sintering with shared catalytic post combustion

Continuous Furnaces

Electrically Heated or Gas-Fired



Continuous furnace plant for working temperatures up to 260 °C with integrated cooling station

Continuous furnace D 1500/3000/300/14 for thermal ageing with mesh belt transport system and subsequent cooling station



Continuous furnaces are the right choice for processes with fixed cycle times such as drying or preheating, curing, aging, vulcanisation or degassing. The furnaces are available for various temperatures up to a maximum of 1400 °C. The furnace design depends on the required throughput, the process requirements for heat treatment and the required cycle time.



Continuous furnace for bulk materials in baskets

The conveyor technology is tailored to the required working temperature, geometry and weight of the charge and to the requirements regarding available space and integration into the process chain. The conveyor speed and the number of control zones are defined by the process specifications.



Roller continuous furnace N 650/45 AS for heat treatment of heavy workparts

Continuous Furnaces

Electrically Heated or Gas-Fired



Conveyor plant D 1600/3100/1200/55, consisting of solution annealing furnace, cooling station and conveyor system



Mesh belt drive in a continuous furnace

Conveyor concepts

- Conveyor belt
- Metal conveyor belt with adjusted mesh gauges
- Drive chain
- Roller conveyors
- Paternoster
- Pusher-type
- Rotary hearth

Heating systems

- Electric heating, radiation or convection
- Direct or indirect gas-fired
- Infrared heating
- Heating with the use of external heat sources



Continuous furnace D 700/10000/300/45S with chain conveyor for 950 °C, gas-fired



Continuous furnace D 1100/3600/100/50 AS for annealing of springs incl. charging and discharging system

Temperature cycles

- Control of working temperature across the whole length of the furnace, such as for drying or preheating
- Automatic control of a process curve applying defined heat-up, dwell and cooling time
- Heat treatment including a final quenching of the charge

Process atmosphere

- In air
- For processes with organic outgasings incl. mandatory safety technology according to EN 1539 (NFPA 86)
- In non-flammable protective or reactive gases such as nitrogen, argon or forming gas
- In flammable protective or reactive gases such as hydrogen incl. the necessary safety technology

Basic configuration criteria

- Conveyor speed
- Temperature uniformity
- Operating temperature
- Process curve
- Work space width
- Charge weights
- Cycle time or throughput
- Length of charge and discharge zone
- Generated exhaust gases
- Specific industry standards such as AMS, CQI-9, FDA etc.
- Other individual customer requirements



Mesh belt drive in continuous furnace D 1100/3600/100/50 AS



Rotary hearth furnace for preheating

Salt-Bath Furnaces for Chemical Hardening of Glass

Electrically Heated



Salt-bath furnace TS 4/50, electrically heated

Chemical hardening is mostly applied for the solidification of thin glasses with a thickness of up to 3 mm. Chemical pretensioning is recommended because the surface flatness can be maintained. Producers of copy machines, solar modules, microwave devices, measuring instruments as well as companies in the lighting industry, the automotive industry and other users of flat glass need to apply the toughest possible glass in their products. Nearly all glasses containing a large percentage of sodium can be strengthened by means of ion exchange.

- Tmax 500 °C, tailored design possible up to Tmax 1000 °C
- Safety technology according to EN 60519-2
- Salt-bath furnace in compact design with salt-bath and pre-heated-/cooling chamber above the salt-bath
- Bath temperature control
- Insulated salt-bath cover
- Indirect heating of the preheated chamber from the salt-bath
- Automatic, time controlled movement from the preheating chamber into the salt-bath and back
- Electrical door lock
- Crucible made of high-quality CrNi steel
- Over-temperature limiter with manual reset in the furnace chamber to prevent dangerous conditions for the furnace or personnel



Insulated cover of the salt-bath

- Defined application within the constraints of the operating instructions
- NTLog Basic for Nabertherm controller: recording of process data with USB-flash drive
- Controls description see page 72

Additional equipment

- Hood for connection to local exhaust system
- Charging basket according to customers drawing
- Active heating for the preheated chamber
- Process control and documentation via Nabertherm Control Center (NCC) for monitoring, documentation and control see page 72



Charging basket

Model	Tmax °C ²	Inner dimensions crucible in mm			Volume in l	Outer dimensions in mm			Heating power in kW ¹	Electrical connection*	Weight in kg
		w	d	h		W	D	H			
TS 4/50	500	180	70	100	4	1600	1050	2400	1.2	3-phase	600
TS 8/50	500	300	100	100	8	1600	1050	2400	2.0	3-phase	650
TS 90/50	500	650	300	450	90	1600	1050	2400	20.0	3-phase	700

¹Depending on furnace design connected load might be higher

²Salt-bath temperature

*Please see page 73 for more information about supply voltage

Chamber Furnaces Electrically Heated



Chamber furnace N 41/H



Chamber furnace N 321 with charging stacker

These universal chamber furnaces with radiation heating have been specifically designed to withstand heavy-duty use in the heat treatment shop. They are particularly useful for processes such as tool making or for hardening jobs, e.g. annealing, hardening and forging. With help of various accessories, these furnaces can be customized to your application requirements.

- Compact, robust design
- Three-sides heating: from both side walls and bottom
- Heating elements on support tubes ensure free heat radiation and a long service life
- Bottom heating protected by heat conducting SiC tiles
- Stainless steel upper door jamb protects furnace structure when furnace is opened hot
- Base frame included in the delivery, N 7/H - N 17/HR designed as table-top model
- Exhaust opening in the side of the furnace, or on rear wall of chamber furnace in the N 31/H models and higher
- Temperature uniformity up to +/- 10 °C according to DIN 17052-1 see page 71
- Low energy consumption due to multi-layer insulation
- Gas spring dampers provide for easy door opening and closing
- Heat resistant zinc paint for protection of door and door frame (for model N 81 and larger)
- Defined application within the constraints of the operating instructions
- NTLog Basic for Nabertherm controller: recording of process data with USB-flash drive
- Controls description see page 72



Production moulds for beer glasses

Model	Tmax °C	Inner dimensions in mm			Volume in l	Outer dimensions in mm			Heating power in kW ³	Electrical connection*	Weight in kg
		w	d	h		W	D	H			
N 7/H ¹	1280	250	250	140	9	800	650	600	3.0	1-phase	60
N 11/H ¹	1280	250	350	140	11	800	750	600	3.5	1-phase	70
N 11/HR ¹	1280	250	350	140	11	800	750	600	5.5	3-phase ²	70
N 17/HR ¹	1280	250	500	140	17	800	900	600	6.4	3-phase ²	90
N 31/H	1280	350	350	250	30	1040	1100	1340	15.0	3-phase	210
N 41/H	1280	350	500	250	40	1040	1250	1340	15.0	3-phase	260
N 61/H	1280	350	750	250	60	1040	1500	1340	20.0	3-phase	400
N 87/H	1280	350	1000	250	87	1040	1750	1340	25.0	3-phase	480
N 81	1200	500	750	250	80	1140	1900	1790	20.0	3-phase	820
N 161	1200	550	750	400	160	1180	1930	1980	30.0	3-phase	910
N 321	1200	750	1100	400	320	1400	2270	2040	47.0	3-phase	1300
N 641	1200	1000	1300	500	640	1690	2670	2240	70.0	3-phase	2100
N 81/13	1300	500	750	250	80	1220	1960	1840	22.0	3-phase	900
N 161/13	1300	550	750	400	160	1260	1990	2030	35.0	3-phase	1000
N 321/13	1300	750	1100	400	320	1480	2330	2090	60.0	3-phase	1500
N 641/13	1300	1000	1300	500	640	1770	2730	2290	80.0	3-phase	2500

¹Table-top model

²Heating only between two phases

*Please see page 73 for more information about supply voltage

³Depending on furnace design connected load might be higher



Chamber furnace N 7/H

Fusing Furnaces with Fixed Table



Fusing furnace GF 600



Exhaust air flap as additional equipment

The fusing furnaces in the GF 75 - GF 1425 product line were conceived for professional glass artists. The heating elements, closely arranged, protected in quartz tubes, ensure a very high degree of temperature uniformity during fusing or during bending across the whole table surface. The insulation, made of non-classified fibrous material in the furnace hood and robust lightweight refractory bricks in the furnace floor allow clean and safe operation. High current connection capacities assure that the fusing furnace can be rapidly heated up.

- Tmax 950 °C
- Heating element, protected in quartz tubes
- High current connection capacities for short warm-up times and energy-saving way of working
- Arranged closely beside each other on the top, heating elements ensure direct and uniform radiation of the glass
- Dual shell hood made of stainless steel with slotted cover lid
- Controller integrated to save space on the right side of the furnace
- Level table surface with insulation made of robust lightweight refractory bricks and marked charge surface
- Hood insulation made of non-classified ceramic fibers for rapid heating up and cooling down



Fusing furnace GF 240



Fusing furnace GF 75

- Adjustable, large quick-release fasteners - can be used while working in gloves
- Handles on the left and right side of the hood for opening and closing the furnace
- Hood safety switch
- Solid state relays provide for low-noise operation
- Rapid switching cycles result in precise temperature control
- Type K thermocouple
- Hood easy to open and close, supported by compressed-gas springs
- Lockable air inlet opening for ventilation, fast cooling and observation of charge
- Robust base on rollers (two of them can be locked down) with tray for glass and tools
- Comfortable charging height of 870 mm
- Defined application within the constraints of the operating instructions
- NTLog for Nabertherm Controller: Recording of process data with USB-flash drive
- Controls description see page 72



"Combing" in a fusing furnace GF 240



Front made of textured stainless steel

Model	Tmax °C	Inner dimensions in mm			Floor space in m ²	Outer dimensions in mm			Heating power in kW ¹	Electrical connection*	Weight in kg
		w	d	h		W	D	H ³			
GF 75	950	620	620	310	0.38	1100	965	1310	3.6	1-phase	180
GF 75 R	950	620	620	310	0.38	1100	965	1310	5.5	3-phase ¹	180
GF 190 LE	950	1010	620	400	0.62	1480	965	1400	6.0	1-phase ²	245
GF 190	950	1010	620	400	0.62	1480	965	1400	6.4	3-phase ¹	245
GF 240	950	1010	810	400	0.81	1480	1155	1400	11.0	3-phase	250
GF 380	950	1210	1100	400	1.33	1680	1465	1400	15.0	3-phase	450
GF 420	950	1660	950	400	1.57	2130	1315	1400	18.0	3-phase	500
GF 520	950	1210	1160	400	1.40	1680	1525	1400	15.0	3-phase	550
GF 600	950	2010	1010	400	2.03	2480	1375	1400	22.0	3-phase	600
GF 920	950	2110	1160	400	2.44	2580	1525	1400	26.0	3-phase	850
GF 1050	950	2310	1210	400	2.79	2780	1575	1400	32.0	3-phase	1050
GF 1425	950	2510	1510	400	3.79	2880	1875	1400	32.0	3-phase	1200

¹Heating only between two phases

²Fusing of 32 A if connected to 230 V

⁴Depending on furnace design connected load might be higher

*Please see page 73 for more information about supply voltage

³Base included



Finished parts out of a fusing furnace

Fusing Furnaces with Movable Table



Fusing furnace GFM 920

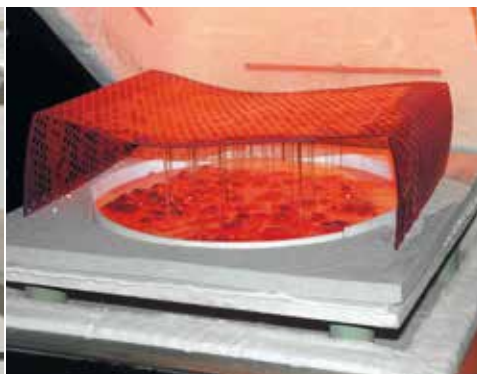
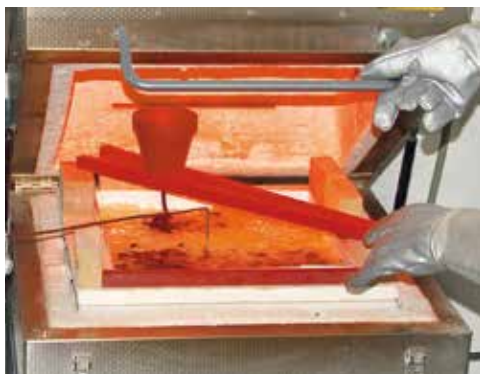

The fusing furnaces of GFM product line were developed to meet the special requirements of production. For different applications different table models can be supplied. Standard is a table for fusing. Various tables and tubs with different heights are available as system add-ons. Especially economical is the alternating table system, in which one table is loaded while the other one is in the fusing furnace.

- Tmax 950 °C
- Heating element, protected in quartz tubes
- High current connection capacities for short warm-up times and energy-saving way of working
- Arranged closely beside each other on the top, heating elements ensure direct and uniform radiation of the glass
- Infrared heated in hood which is attached to stand
- Dual shell hood made of stainless steel with slotted cover lid
- Delivered with table
- Table on wheels, freely movable
- Controller integrated to save space on the right side of the furnace
- Level table surface with insulation made of robust lightweight refractory bricks and marked charge surface
- Hood insulation made of non-classified ceramic fibers for rapid heating up and cooling down
- Adjustable, large quick-release fasteners - can be used while working in gloves
- Handles on the left and right side of the hood for opening and closing the furnace
- Hood safety switch
- Solid state relays provide for low-noise operation
- Type K thermocouple
- Hood easy to open and close, supported by compressed-gas springs
- Lockable air inlet opening for ventilation, fast cooling and observation of charge
- Comfortable charging height of 870 mm
- Defined application within the constraints of the operating instructions
- NTLog for Nabertherm Controller: Recording of process data with USB-flash drive
- Controls description see page 72

Additional features for fusing furnaces GF and GFM

- Motor-driven lid opening for faster cooling for models GF 380 and/or GFM 420 up
- Bottom heating for uniform through heating of large objects
- Cooling fan for accelerated cooling with closed lid
- Tables for expansion of the furnace system for models GFM; Interchangeable table system to use the residual heat of the furnace and to reduce cycle times by changing table in warm state.
- Motor-driven exhaust air flap for faster cooling of the fusing furnace
- Air inlet flap with window for observing the glass
- Process control and documentation via VCD software package for monitoring, documentation and control see page 75

Model	Tmax °C	Inner dimensions in mm			Floor space in m ²	Outer dimensions in mm			Heating power in kW ¹	Electrical connection*	Weight in kg
		w	d	h		W	D	H			
GFM 420	950	1660	950	400	1.57	2170	1340	1400	18	3-phase	630
GFM 520	950	1210	1160	400	1.40	1720	1440	1400	15	3-phase	660
GFM 600	950	2010	1010	400	2.03	2530	1400	1400	22	3-phase	730
GFM 920	950	2110	1160	400	2.44	2630	1550	1400	26	3-phase	980
GFM 1050	950	2310	1210	400	2.79	2830	1600	1400	32	3-phase	1190
GFM 1425	950	2510	1510	400	3.79	3030	1900	1400	32	3-phase	1390

¹Depending on furnace design connected load might be higher

*Please see page 73 for more information about supply voltage



Bottom heating for uniform through heating of large objects as additional equipment



Tables for expansion of the furnace system as additional equipment; Interchangeable table system to use the residual heat of the furnace and to reduce cycle times by changing table in warm state

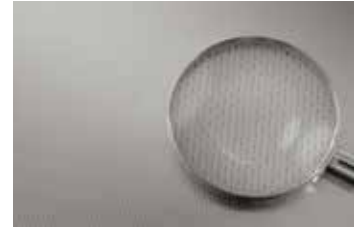

Front made of textured stainless steel



Motor-driven lid as additional equipment



Inspection glass in air inlet opening for observation of the glass as additional equipment

Tub Furnaces with Wire Heating

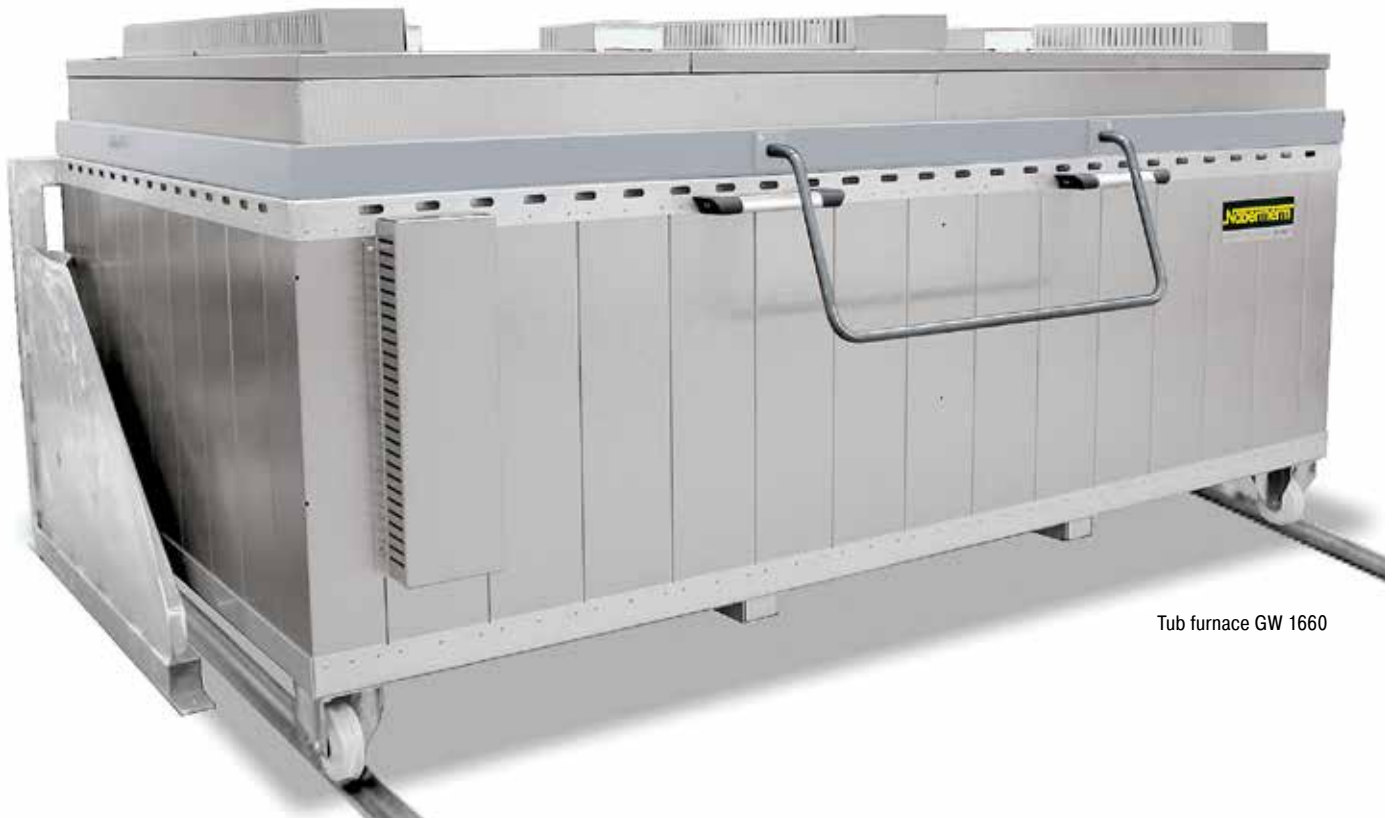

Tub furnace GW 1660



Bottom heating covered by SiC tiles to create level stacking support

For slumping and bending of complex glass parts, e.g. glass furniture, shower cabins, etc., tub furnaces are the right choice. Full coverage heating: from the lid, all 4 sides and the tub bottom. Due to the modular system additional tubs in customized dimensions can be provided.

- Tmax 900 °C
- Full coverage heating: from lid, all 4 sides and bottom
- 3-zone temperature control from top to bottom for optimal temperature uniformity
- Heating elements mounted on ceramic support tubes for free heat radiation and long service life
- Bottom heating covered by SiC tiles
- Hood insulated with non-classified fiber materials



Tub furnace GW 2200

- Tub bottom insulated with multi-layer of insulation, lightweight refractory bricks on the hot face
- Hinged hood as standard version
- Gas operated dampers provide for easy hood opening
- Manually operated exhaust air flaps
- Tub on wheels can be pulled out manually
- Rails on floor for perfect tub guidance included
- Defined application within the constraints of the operating instructions
- Controls description see page 72

Additional equipment

- Interchangeable table system on rails, electrically driven on request
- Electro-hydraulically driven hood instead of hinged cover
- Tub insert to elevate bottom height, in order to use the furnace for glass fusing applications (in this product version the tub heating can be switched off)



Top hat furnace GW 2208/S with electro-hydraulically driven hood, tub can be pulled out on rails

- Automatic lid opening for faster cooling, programmable via the controller extra function
- Motor-driven exhaust air flaps in the hood for preselected cooling
- Powerful cooling system

An efficient fan system, mounted to the furnace, cools the dual shell housing from the back. This system shortens cooling times by up to 50 % subject to cycles and charge. Direct contact between the cooling air and charge, hence turbulences in the firing chamber are avoided, protecting the glass from any damage.

- Interchangeable table system running on rails
- To shorten process times and optimise operational capacity, two or more furnace tubs, placed alternately under the hood, can be used. An automatic tub changing system is also available on request.
- Process control and documentation via Nabertherm Control Center (NCC) for monitoring, documentation and control see page 72



Automatic lid opening via electromechanical spindle



Motor-driven exhaust air flaps as additional equipment

Model	Tmax °C	Inner dimensions in mm			Volume in l	Outer dimensions in mm			Heating power in kW ¹	Electrical connection*	Weight in kg
		w	d	h		W	D	H			
GW 830	900	1200	1150	600	830	2140	1980	1250	36	3-phase	820
GW 840	900	1650	850	600	840	2590	1680	1250	36	3-phase	980
GW 1200	900	2000	1000	600	1200	2940	1830	1250	40	3-phase	1210
GW 1500	900	2100	1150	600	1450	3040	1980	1250	70	3-phase	1420
GW 1660	900	2300	1200	600	1660	3240	2030	1250	80	3-phase	1780
GW 2200	900	2300	1200	800	2200	3240	2030	1400	90	3-phase	2160
GW 8000	900	3700	2700	800	8000	4640	3530	1400	180	3-phase	2980

¹Depending on furnace design connected load might be higher

*Please see page 73 for more information about supply voltage



Tub furnace GW 1660

Top Hat Furnaces with Wire Heating with Table



Top hat furnace HG 5208/S with two tables for bending and slumping of glass

Nabertherm markets this range of top hat furnaces for bending and slumping of large glass parts. The top hat furnace is equipped with one table running on rails which can be pulled out for easy charging. As accessory an additional table can be integrated, which is charged while the other table is in the furnace. The top hat furnaces are heated from the ceiling and from the table.



- Tmax 900 °C
- Heating from lid and table
- 3-zone temperature control (lid-inner circular element, lid-outer circular element, table) for optimal temperature uniformity
- Table heating can be switched-off for fusing
- Heating elements on supporting tubes provide for long service life
- Table heating elements covered by SiC tiles for level stacking support
- Hood insulated with non-classified fiber materials
- Table insulated with multi-layer resistant, lightweight refractory bricks
- Top hat to be opened by overhead crane in floor shop
- Protection guides for easy top hat opening and closing

Top hat furnace HG 2000



Top hat furnace HG 1196/S with top hat and table heating; table heating can be switched-off during fusing

- Manually-operated exhaust air flap
- Furnace table on fixed chassis for user-friendly charging height (approx. 800 mm)
- Defined application within the constraints of the operating instructions
- NTLog for Nabertherm Controller: Recording of process data with USB-flash drive
- Controls description see page 72

Additional equipment

- Top hat side heating in case of high top hat dimensions
- Design without table heating or with disengageable table heating for fusing
- Interchangeable table system on rails, electrically powered on request
- Electro-hydraulically driven top hat
- Cooling system
- Table on wheels for free movement
- Motor-driven exhaust air flaps
- Process control and documentation via Nabertherm Control Center (NCC) for monitoring, documentation and control see page 72



Motor-driven exhaust air flaps as additional equipment

Model	Tmax °C	Inner dimensions in mm			Floor space in m ²	Outer dimensions in mm			Heating power in kW ¹	Electrical connection*	Weight in kg
		w	d	h		W	D	H			
HG 750	900	2100	1200	300	2.52	2550	1800	1350	35	3-phase	1200
HG 1000	900	1750	1000	550	1.75	2200	1450	1600	33	3-phase	1500
HG 1500	900	2100	1250	550	2.63	2550	1700	1600	44	3-phase	2000
HG 1800	900	2450	1850	400	4.35	2950	2350	1600	45	3-phase	2500
HG 2000	900	2450	1500	550	3.68	2900	1950	1600	55	3-phase	2500
HG 2640	900	3000	2200	400	6.60	3500	2700	1450	75	3-phase	3400
HG 3000	900	3500	2200	400	7.70	4000	2800	1600	75	3-phase	3800
HG 4800	900	5500	2100	400	11.55	6000	2700	1600	90	3-phase	4500
HG 5208/S	900	3100	2100	800	6.51	3990	2590	3140	110	3-phase	5000
HG 7608/S	900	3800	2500	800	9.50	4690	2990	3140	143	3-phase	7000

¹Depending on furnace design connected load might be higher

*Please see page 73 for more information about supply voltage



Heating elements in furnace hood

Hot-Wall Retort Furnaces up to 1100 °C



Retort furnace NRA 25/06 with gas supply system



Retort furnace NRA 150/09 with automatic gas injection and process control H3700



Inside heating in retort furnaces NRA ../06

These gas tight retort furnaces are equipped with direct or indirect heating depending on temperature. They are perfectly suited for various heat treatment processes requiring a defined protective or a reaction gas atmosphere. These compact models can also be laid out for heat treatment under vacuum up to 600 °C. The furnace chamber consists of a gas tight retort with water cooling around the door to protect the special sealing. Equipped with the corresponding safety technology, retort furnaces are also suitable for applications under reaction gases, such as hydrogen or, in combination with the IDB package, for inert debinding or for pyrolysis processes.

Different model versions are available depending on the temperature range required for the process:

Models NRA ../06 with Tmax 650 °C

- Heating elements located inside the retort
- Temperature uniformity up to +/- 5 °C inside the work space see page 71
- Retort made of 1.4571
- Gas circulation fan in the back of the retort provides for optimal temperature uniformity

Models NRA ../09 with Tmax 950 °C

- Outside heating with heating elements around the retort
- Temperature uniformity up to +/- 5 °C inside the work space see page 71
- Retort made of 1.4841
- Fan in the back of the retort provides for optimal temperature uniformity

Models NR ../11 with Tmax 1100 °C

- Outside heating with heating elements around the retort
- Temperature uniformity up to +/- 5 °C inside the work space see page 71
- Retort made of 1.4841



Bayonet quick-lock for the retort, also with electric drive as additional equipment



Parallel guided door to open the hot retort furnace as additional equipment



Retort furnace NRA 25/09



Retort furnace NRA 50/09 H₂

Basic version

- Compact housing in frame design with removable stainless steel sheets
- Controls and gas supply integrated in the furnace housing
- Welded charging supports in the retort or air-baffle box in the furnace with atmosphere circulation
- Swivel door hinged on right side with open cooling water system
- Depending on furnace volume for 950 °C- and 1100 °C-version the control system is divided in one or more heating zones
- Temperature control as furnace control with temperature measurement outside the retort
- Gas supply system for one non-flammable protective or reaction gas with flow meter and manual valve
- Port for vacuum pump for cold evacuation
- Operation under vacuum up to 600 °C with optional single-stage rotary vane pump
- Defined application within the constraints of the operating instructions
- NTLog Basic for Nabertherm controller: recording of process data with USB-flash drive
- Controls description see page 72



Vacuum pump for cold evacuation of the retort

Additional equipment

- Upgrade for other non-flammable gases
- Automatic gas injection, including MFC flow controller for alternating volume flow, controlled with process control H3700, H1700
- Vacuum pump for evacuating of the retort up to 600 °C, attainable vacuum up to 10⁻⁵ mbar subject to selected pump
- Cooling system for shortening process times
- Heat exchanger with closed-loop cooling water circuit for door cooling
- Measuring device for residual oxygen content
- Door heating
- Temperature control as charge control with temperature measurement inside and outside the retort
- Gas inlet with solenoid valve, controlled by the program
- Process control and documentation via VCD software package or Nabertherm Control Center (NCC) for monitoring, documentation and control see page 72



Process control H3700 for automatic version

Hot-Wall Retort Furnaces up to 1100 °C



Retort furnace NRA 300/09 H₂ for heat treatment under hydrogen



Charging of the retort furnace NRA 300/06 furnace with a pallet truck

H₂ Version for Operation with Flammable Process Gases

When a flammable process gas like hydrogen is used, the retort furnace is additionally equipped with the required safety technology. Only certified and industry proven safety sensors are used. The furnace is controlled by a fail-safe PLC control system (S7- 300F/safety controller).

- Supply of flammable process gas at controlled overpressure of 50 mbar relative
- Certified safety concept
- PLC controls with graphic touch panel H 3700 for data input
- Redundant gas inlet valves for hydrogen
- Monitored pre-pressures of all process gases
- Bypass for safe flushing of furnace chamber with inert gas
- Torch for thermal post combustion of exhaust gases
- Emergency flood container for purging the furnace in case of failure

IDB Version for Debinding under Non-flammable Protective Gases or for Pyrolysis Processes

The retort furnaces of the NR and NRA product line are perfectly suited for debinding under non-flammable protective gases or for pyrolysis processes. The IDB version of the retort furnaces implements a safety concept by controlled purging the furnace chamber with a protective gas. Exhaust gases are burned in an exhaust torch. Both the purging and the torch function are monitored to ensure a safe operation.

- Process control under monitored and controlled overpressure of 50 mbar relative
- Process control H 1700 with PLC controls and graphic touch panel for data input
- Monitored gas pre-pressure of the process gas
- Bypass for safe flushing of furnace chamber with inert gas
- Torch for thermal post combustion of exhaust gases



Retort furnace NR 150/11 IDB with thermal post combustion

Model	Tmax °C	Model	Tmax °C	Work space dimensions in mm			Work space in l	Electrical connection*
				w	d	h		
NRA 17/..	650 or 950	NR 17/11	1100	225	350	225	17	3-phase
NRA 25/..	650 or 950	NR 25/11	1100	225	500	225	25	3-phase
NRA 50/..	650 or 950	NR 50/11	1100	325	475	325	50	3-phase
NRA 75/..	650 or 950	NR 75/11	1100	325	700	325	75	3-phase
NRA 150/..	650 or 950	NR 150/11	1100	450	750	450	150	3-phase
NRA 200/..	650 or 950	NR 200/11	1100	450	1000	450	200	3-phase
NRA 300/..	650 or 950	NR 300/11	1100	590	900	590	300	3-phase
NRA 400/..	650 or 950	NR 400/11	1100	590	1250	590	400	3-phase
NRA 500/..	650 or 950	NR 500/11	1100	720	1000	720	500	3-phase
NRA 700/..	650 or 950	NR 700/11	1100	720	1350	720	700	3-phase
NRA 1000/..	650 or 950	NR 1000/11	1100	870	1350	870	1000	3-phase

*Please see page 69 for more information about supply voltage



The retort furnaces SR and SRA (with gas circulation) are designed for operation with non-flammable or flammable protective or reaction gases. The furnace is loaded from above by crane or other lifting equipment provided by the customer. In this way, even large charge weights can be loaded into the furnace chamber.

Depending on the temperature range in which the furnace be used, the following models are available:

Models SR .../11 with Tmax 1100 °C

- Heating from all sides outside the retort
- Temperature uniformity up to +/- 5 °C inside the work space see page 71
- Retort made of 1.4841
- Top down multi-zone control of the furnace heating

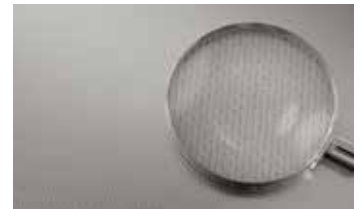

Front made of textured stainless steel

Models SRA/09 with Tmax 950 °C

Design like models SR.../11 with following differences:

- Atmosphere circulation with powerful fan in the furnace lid provides for temperature uniformity of up to +/- 5 °C inside the work space see page 71

Retort furnace SRA 300/06 with charging basket

Models SRA/06 with Tmax 600 °C

Design like models SRA.../09 with following differences:

- Heating inside the retort
- Temperature uniformity up to +/- 5 °C inside the work space see page 71
- Single-zone control
- Retort made of 1.4841

Standard Equipment (all models)

Design like standard equipment of models NR and NRA with following differences:

- Charging from above with crane or other lifting equipment from customer
- Hinged lid with opening to the side
- Defined application within the constraints of the operating instructions
- NTLog Basic for Nabertherm controller: recording of process data with USB-flash drive

Additional equipment, H₂ version or IDB version see models NR and NRA



Retort furnace SR 170/1000/11 with changeable retort and cooling station

Model	Tmax °C	Inner dimensions of alloy retort		Volume in l	Outer dimensions in mm			Electrical connection*	Weight in kg
		ø in mm	h in mm		W	D	H		
SR(A) 17/..	600, 950 or 1100	250	350	17	1300	1700	1800	3-phase	600
SR(A) 25/..		250	500	25	1300	1900	1800	3-phase	800
SR(A) 50/..		400	450	50	1400	2000	1800	3-phase	1300
SR(A) 100/..		400	800	100	1400	2000	2100	3-phase	1500
SR(A) 200/..		600	700	200	1600	2200	2200	3-phase	2100
SR(A) 300/..		600	1000	300	1600	2200	2500	3-phase	2400
SR(A) 500/..		800	1000	500	1800	2400	2700	3-phase	2800
SR(A) 600/..		800	1200	600	1800	2400	2900	3-phase	3000
SR(A) 800/..		1000	1000	800	2000	2600	2800	3-phase	3100
SR(A) 1000/..		1000	1300	1000	2000	2600	3100	3-phase	3300
SR(A) 1500/..		1200	1300	1500	2200	2800	3300	3-phase	3500

*Please see page 73 for more information about supply voltage



Retort furnace SRA 200/09

Cold-Wall Retort Furnaces up to 2400 °C



Retort furnace VHT 500/22-GR H₂ with CFC-process box and extension package for operation under hydrogen

The compact retort furnaces of the VHT product line are available as electrically heated chamber furnaces with graphite, molybdenum, tungsten or MoSi₂ heating. A wide variety of heating designs as well as a complete range of accessories provide for optimal retort furnace configurations even for sophisticated applications.

The vacuum-tight retort allows heat treatment processes either in protective and reaction gas atmospheres or in a vacuum, subject to the individual furnace specs to 10⁻⁵ mbar. The basic furnace is suited for operation with non-flammable protective or reactive gases or under vacuum. The H₂ version provides for operation under hydrogen or other flammable gases. Key of the specification up is a certified safety package providing for a safe operation at all times and triggers an appropriate emergency program in case of failure.

Alternative Heating Specifications

In general the following variants are available with respect to the process requirements:

VHT ...-GR with Graphite Insulation and Heating

- Suitable for processes under protective and reaction gases or under vacuum
- Tmax 1800 °C or 2200 °C (2400 °C as additional equipment)
- Max. vacuum up to 10⁻⁴ mbar depending on pump type used
- Graphite felt insulation

VHT ...-MO or VHT ...-W with Molybdenum or Tungsten Heating

- Suitable for high-purity processes under protective and reaction gases or under high vacuum
- Tmax 1200 °C, 1600 °C or 1800 °C (see table)
- Max. vacuum up to 10⁻⁵ mbar depending on pump type used
- Insulation made of molybdenum resp. tungsten radiation sheets

VHT ...-KE with Fiber Insulation and Heating through Molybdenum Disilicide Heating Elements

- Suitable for processes under protective and reaction gases, in air or under vacuum
- Tmax 1800 °C
- Max. vacuum up to 10⁻² mbar (up to 1300 °C) depending on pump type
- Insulation made of high purity aluminum oxide fiber



Retort furnace VHT 100/15-KE H₂ with fiber insulation and extension package for operation under hydrogen, 1400 °C



Heat treatment of copper bars under hydrogen in retort furnace VHT 8/16-MO

Standard Equipment for all Models

Basic version

- Standard furnace sizes 8 - 500 liters
- A water-cooled stainless steel process reactor sealed with temperature-resistant o-rings
- Frame made of stable steel profiles, easy to service due to easily removable stainless steel panels
- Housing of the VHT 8 model on castors for easy repositioning of furnace
- Cooling water manifold with manual stopcocks in supply and return lines, automatic flowmeter monitoring, openloop cooling water system
- Adjustable cooling water circuits with flowmeter and temperature indicator and overtemperature fuses
- Switchgear and controller integrated in furnace housing
- Over-temperature limiter with adjustable cutout temperature for thermal protection class 2 in accordance with EN 60519-2
- Manual operation of the process gas and vacuum functions
- Manual gas supply for one process gas (N_2 , Ar or non-flammable forming gas) with adjustable flow
- Bypass with manual valve for rapid filling or flooding of furnace chamber
- Manual gas outlet with overflow valve (20 mbar relative) for over-pressure operation
- Single-stage rotary vane pump with ball valve for pre-evacuating and heat treatment in a rough vacuum to 5 mbar
- Pressure gauge for visual pressure monitoring
- Defined application within the constraints of the operating instructions

Additional equipment

- Tmax 2400 °C for VHT 40/...-GR and larger
- Housing, optionally divisible, for passing through narrow door frames (VHT 08)
- Manual gas supply for second process gas (N_2 , Ar or non-flammable forming gas) with adjustable flow and bypass
- Inner process box made of molybdenum, tungsten, graphite or CFC, especially recommended for debinding processes. The box is installed in the furnace with direct gas inlet and outlet and provides for better temperature uniformity. Generated exhaust gases will be directly lead out the inner process chamber during debinding. The change of gas inlet pathes after debinding results in a cleaned process gas atmosphere during sintering.
- Charge thermocouple with display
- Temperature measurement at 2200 °C models with pyrometer and thermocouple, type S with automatic pull-out device for precise control results in the low temperature range (VHT 40/...-GR and larger)
- Two-stage rotary vane pump with ball valve for pre-evacuating and heat-treating in a fine vacuum (up to 10^2 mbar)
- Turbo molecular pump with slide valve for pre-evacuation and for heat treatment in a high vacuum (up to 10^5 mbar) including electric pressure transducer and booster pump
- Other vacuum pumps on request
- Heat exchanger with closed-loop cooling water circuit
- Automation package with process control H3700
 - 12" graphic touch panel
 - Input of all process data like temperatures, heating rates, gas injection, vacuum at the touch panel
 - Display of all process-relevant data on a process control diagram
 - Automatic gas supply for one process gas (N_2 , Ar or non-flammable forming gas) with adjustable flow
 - Bypass for flooding and filling the chamber with process gas controlled by the program
 - Automatic pre- and post programs, including leak test for safe furnace operation
 - Automatic gas outlet with bellows valve and overflow valve (20 mbar relative) for over-pressure operation
 - Transducer for absolute and relative pressure
- Mass flow controller for alternating volume flow and generation of gas mixtures with second process gas (only with automation package)
- Partial pressure operation: protective gas flushing at controlled underpressure (only with automation package)
- Process control and documentation via VCD software package or Nabertherm Control Center (NCC) for monitoring, documentation and control see page 72



Graphite heating chamber



Molybdenum heating chamber



Tungsten heating chamber



Ceramic fiber insulation



Thermocouple, type S with automatic pull-out device for precise control results in the low temperature range



Retort furnace VHT 8/16-MO with automation package



Retort furnace VHT 40/22-GR with motor-driven lift door and front frame for connection to a glovebox



Turbo-molecular pump

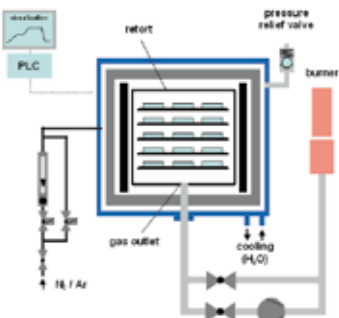

VHT gas supply diagram, debinding and sintering

H₂ Version for Operation with Hydrogen or other Reaction Gases

In the H₂ version the retort furnaces can be operated under hydrogen or other reaction gases. For these applications, the systems are additionally equipped with the required safety technology. Only certified and industry proven safety sensors are used. The retort furnaces are controlled by a fail-safe PLC control system (S7-300F/safety controller).

- Certified safety concept
- Automation package (additional equipment see page 57)
- Redundant gas inlet valves for hydrogen
- Monitored pre-pressures of all process gases
- Bypass for safe purging of furnace chamber with inert gas
- Pressure-monitored emergency flooding with automated solenoid valve opening
- Electric or gas-fired exhaust gas torch for H₂ post combustion
- Atmospheric operation: H₂-purging of process reactor starting from room temperature at controlled over pressure (50 mbar relative)

Additional equipment

- Partial pressure operation: H₂ flushing at underpressure in the process reactor starting from 750 °C furnace chamber temperature
- Inner process hood in the process chamber for debinding under hydrogen
- Process control and documentation via Nabertherm Control Center (NCC) for monitoring, documentation and control see page 72



Single-stage rotary vane pump for heat treatment in a rough vacuum to 5 mbar



Two-stage rotary vane pump for heat treatment in a vacuum to 10⁻² mbar



Turbo-molecular pump with booster pump for heat treatment in a vacuum to 10⁻⁵ mbar

Process Box for Debinding in Inert Gas

Certain processes require charges to be debinded in non-flammable protective or reactive gases. For these processes we fundamentally recommend a hot-wall retort furnace (see models NR... or SR...). These retort furnaces can ensure that the formation of condensation will be avoided as thoroughly as possible.

If there is no way to avoid the escape of small amounts of residual binder during the process, even in the VHT furnace, the retort furnace should be designed to meet this contingency.

The furnace chamber is equipped with an additional process box that has a direct outlet to the exhaust gas torch through which the exhaust gas can be directly vented. This system enables a substantial reduction in the amount of furnace chamber contamination caused by the exhaust gases generated during debinding.

Depending on the exhaust gas composition the exhaust gas line can be designed to include various options.

- Exhaust gas torch for burning off the exhaust gas
- Condensation trap for separating out binding agents
- Exhaust gas post-treatment, depending on the process, via exhaust gas washer
- Heated exhaust gas outlet to avoid condensation deposits in the exhaust gas line



	VHT .../...-GR	VHT .../...-MO	VHT .../18-W	VHT .../18-KE
Tmax	1800 °C or 2200 °C	1200 °C or 1600 °C	1800 °C	1800 °C
Inert gas	✓	✓	✓	✓
Air/Oxygen	-	-	-	✓
Hydrogen	✓ ^{3,4}	✓ ³	✓ ³	✓ ^{1,3}
Rough vacuum and fine vacuum (>10 ⁻³ mbar)	✓	✓	✓	✓ ²
High vacuum (<10 ⁻³ mbar)	✓ ⁴	✓	✓	✓ ²
Material of heater	Graphite	Molybdenum	Tungsten	MoSi ₂
Material of insulation	Graphite felt	Molybdenum	Tungsten/Molybdenum	Ceramic fiber

¹Tmax reduces to 1400 °C

²Depending on Tmax

³Only with safety package for flammable gases

⁴Up to 1800 °C

Retort furnace VHT 40/16-MO H₂ with hydrogen extension package and process box

Model	Inner dimensions of process box in mm			Volume in l
	w	d	h	
VHT 8/..	120	210	150	3,5
VHT 40/..	250	430	250	25,0
VHT 70/..	325	475	325	50,0
VHT 100/..	425	500	425	90,0
VHT 250/..	575	700	575	230,0
VHT 500/..	725	850	725	445,0



Front made of textured stainless steel

Model	Inner dimensions in mm			Volume in l	Max. charge weight/kg	Outer dimensions in mm			Heating power in kW ⁴			
	w	d	h			W	D	H	Graphite	Molybdenum	Tungsten	Ceramic fiber
VHT 8/..	170	240	200	8	5	1250 (800) ¹	1100	2000	27	19/34 ³	50	12
VHT 40/..	300	450	300	40	30	1600	2100	2300	83/103 ²	54/60 ³	130	30
VHT 70/..	375	500	375	70	50	1700	2500	2400	105/125 ²	70/100 ³	150	55
VHT 100/..	450	550	450	100	75	1900	2600	2500	131/155 ²	90/140 ³	on request	85
VHT 250/..	600	750	600	250	175	3000 ¹	4300	3100	180/210 ²	on request	on request	on request
VHT 500/..	750	900	750	500	350	3200 ¹	4500	3300	220/260 ²	on request	on request	on request

¹With separated switching system unit

²1800 °C/2200 °C

³1200 °C/1600 °C

⁴Depending on furnace design connected load might be higher

Cold-Wall Retort Furnaces up to 2400 °C or up to 3000 °C



Retort furnace SVHT 9/24-W with tungsten heating

Compared with the VHT models (page 56 ff), the retort furnaces of the SVHT product line offer improved performance data with regard to achievable vacuum and maximum temperature. Due to the design as pit-type furnace with tungsten heating, processes up to max. 2400 °C even in high vacuum can be implemented with retort furnaces of the SVHT..-W product line. Retort furnaces of the SVHT..-GR product line with graphite heating, also in pit-type design, can be operated in an inert gas atmosphere even up to max. 3000 °C.

- Standard sizes with a furnace chamber of 2 or 9 liters
- Designed as pit-type furnace, charged from above
- Frame construction with inserted sheets of textured stainless steel
- Dual shell water-cooled stainless steel container
- Manual operation of process gas and vacuum functions
- Manual gas supply for non-flammable process gas
- A step in front of the retort furnace for an ergonomic charging height
- Retort lid with gas-charged shock absorbers
- Controls and switchgear as well as gas supply integrated in furnace housing



Graphite heating module

- Defined application within the constraints of the operating instructions
- Further standard product characteristics see description for standard design of VHT models page 56

Heating options

SVHT ..-GR

- Applicable for processes:
 - Under protective or reaction gases or in the vacuum up to 2200 °C under consideration of relevant max. temperature limits
 - Under inert gas argon up to 3000 °C
- Max. vacuum up to 10⁻⁴ mbar depending on the type of pump used
- Heating: graphite heating elements in cylindrical arrangement
- Insulation: graphite felt insulation
- Temperature measurement by means of an optical pyrometer



Cylindrical retort with tungsten heating

SVHT ..-W

- Applicable for processes under protective or reaction gases or in vacuum up to 2400 °C
- Max. vacuum up to 10⁻⁵ mbar depending on the type of pump used
- Heating: cylindrical tungsten heating module
- Insulation: tungsten and molybdenum radiant plates
- Temperature measurement with thermocouple type C

Additional equipment such as automatic process gas control or design for the operation with flammable gases incl. safety system see VHT models page 56.



Cooling water distribution

Model	Tmax °C	Work space dimensions Ø x h in mm	Useful volume in l	Outer dimensions in mm			Heating power in KW ¹	Electrical connection*
				W	D	H		
SVHT 2/24-W	2400	150 x 150	2,5	1300	2500	2000	55	3-phase
SVHT 9/24-W	2400	230 x 230	9,5	1400	2900	2100	95	3-phase
SVHT 2/30-GR	3000	150 x 150	2,5	1400	2500	2100	65	3-phase
SVHT 9/30-GR	3000	230 x 230	9,5	1500	2900	2100	115	3-phase

¹Depending on furnace design connected load might be higher

*Please see page 73 for more information about supply voltage

Bottom Loading Retort Furnace up to 2400 °C



Retort furnace LBVHT 250/20-WO with tungsten heating chamber

The LBVHT model series with bottom loading specification are especially suitable for production processes which require either protective or reaction gase atmosphere or a vacuum. The basic performance specifications of these models are similar to the VHT models. Their size and design with electro-hydraulically driven table facilitate charging during production. The retort furnaces are available in various sizes and designs. Similar like the VHT models, these furnaces can be equipped with different heating concepts.

- Standard furnace sizes between 100 and 600 liters
- Designed as bottom loading retort furnace with electro-hydraulically driven table for easy and well-arranged charging
- Prepared to carry heavy charge weights
- Different heating concepts using
 - Graphite heating chamber up to Tmax 2400 °C
 - Molybdenum heating chamber up to Tmax 1600 °C
 - Tungsten heating chamber up to Tmax 2000 °C
- Frame structure filled with textured stainless steel sheets
- Standard design with gassing system for non-flammable protective or reaction gases
- Automatic gas supply system which also allows for operation with several process gases as additional equipment
- Gas supply systems for operating with hydrogen or other flammable reaction gases incl. safety package as additional equipment
- Switchgear and control box as well as gassing system integrated into the furnace housing
- Defined application within the constraints of the operating instructions
- Further product characteristics of the standard furnace as well as possible additional equipment can be found in the description of the VHT furnaces from Page 56

Model	Tmax °C	Model	Tmax °C	Model	Tmax °C	Inner dimensions in mm		Volume in l	Electrical connection*
						Ø	h		
LBVHT 100/16-MO	1600	LBVHT 100/20-WO	2000	LBVHT 100/24-GR	2400	450	700	100	3-phase
LBVHT 250/16-MO	1600	LBVHT 250/20-WO	2000	LBVHT 250/24-GR	2400	600	900	250	3-phase
LBVHT 600/16-MO	1600	LBVHT 600/20-WO	2000	LBVHT 600/24-GR	2400	800	1200	600	3-phase

*Please see page 73 for more information about supply voltage



Retort furnace LBVHT 600/24-GR



Retort furnace LBVHT with graphite heating chamber

Catalytic and Thermal Post Combustion, Exhaust Gas Washer



Catalytic post combustion independent from furnace model for refitting on existing plants

For exhaust gas cleaning, in particular in debinding, Nabertherm offers exhaust gas cleaning systems tailored to the process. The post combustion is permanently connected to the exhaust gas fitting of the furnace and accordingly integral part of the control system and the safety matrix of the furnace. For existing furnaces, independent exhaust gas cleaning systems are also available that can be separately controlled and operated.

Catalytic post combustion (KNV)

Catalytic exhaust cleaning is recommended due to energetic reasons when only pure hydrocarbon compounds must be cleaned during the debinding process in air. They are recommended for small to medium exhaust gas amounts.

- Perfectly suited for debinding processes in air with only organic exhaust gases
- Decomposition of gases in carbon dioxide and water
- Integrated in a compact stainless steel housing
- Electric heating provides for preheating of the exhaust gas to the optimal reaction temperature for catalytic treatment
- Cleaning in different layers of catalytic honeycombs within the system
- Thermocouples for measuring the temperatures of raw gas, reaction honeycombs and discharge
- Over-temperature limiter with adjustable cutout temperature protects the catalyst
- Tight connection between the exhaust gas outlet of the debinding furnace and the exhaust gas fan with corresponding integration into the overall system with respect to control and safety technology
- Catalyst dimensioned in relation to the exhaust gas flow
- Measuring port for clean gas measurements (FID)



Forced convection chamber furnace NA 500/65 DB200 with catalytic post combustion

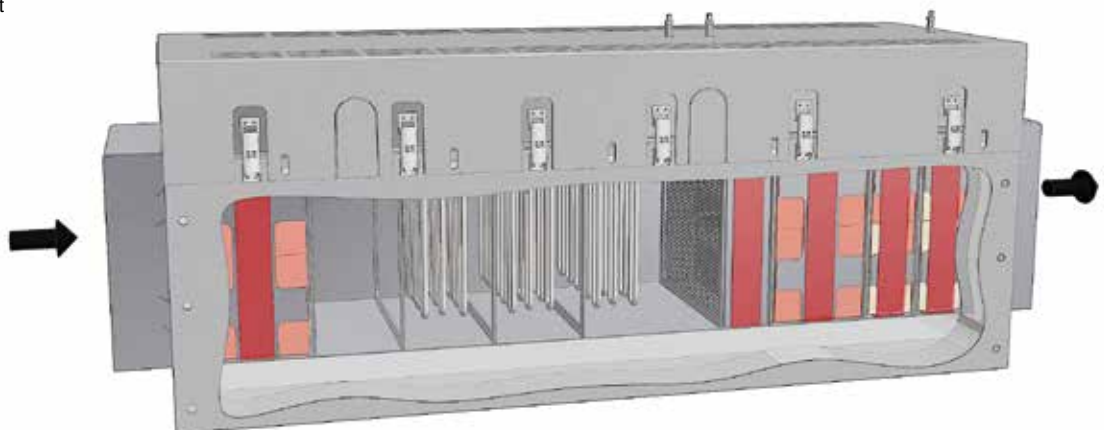

Scheme of a catalytic post combustion

Thermal post combustion (TNV)

Thermal post combustion are used if large volumes of exhaust gas from the debinding process in air must be cleaned and/or if there is a risk that the exhaust gases might damage the catalyst. Thermal post combustion is also used for debinding applications under non-flammable or flammable protective or reaction gases.

- Optimally suited for debinding processes in air with large exhaust gas flow, erratic large exhaust gas volumes, large volume flow or for debinding processes under non-flammable or flammable protective or reaction gases
- Gas-fired to burn the exhaust gases
- Burn-off at temperatures up to 850 °C provides for thermal decomposition of the exhaust gases
- Heating with compact gas burner with automatic firing device
- Thermocouples in the combustion chamber and in the raw gas inlet
- Over-temperature limiter for protecting the thermal post combustion
- Design depending on the exhaust gas flow
- Measuring port for clean gas measurements (FID)



Forced convection furnace
NA 500/06 DB200-2 with thermal post
combustion

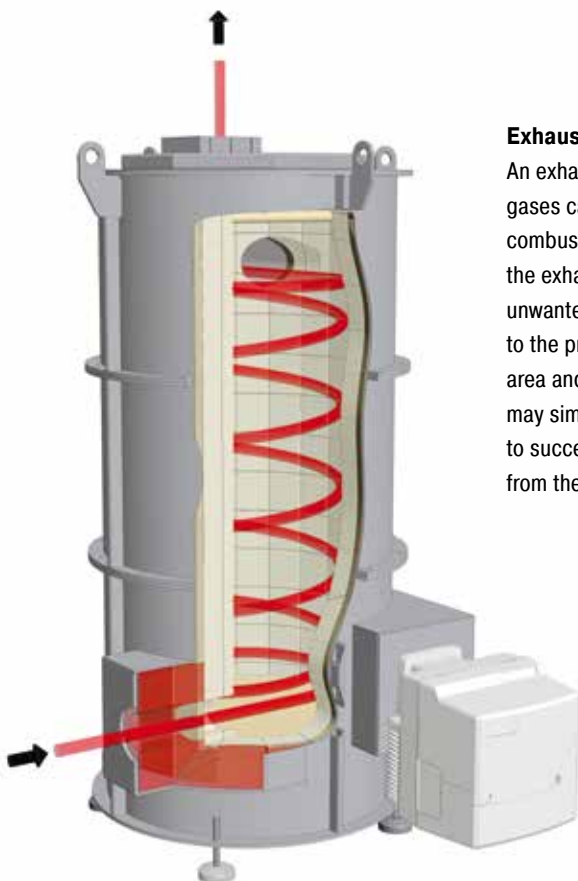

Scheme of a thermal post combustion

Exhaust gas washer

An exhaust gas washer will be often used if the generated gases cannot be effectively treated with a thermal post combustion or with a torch. To clean, detox or decontaminate the exhaust gas stream a liquid is used to wash or neutralize unwanted pollutants. The exhaust gas washer can be adapted to the process by designing its liquid distribution and contact area and by selecting the most suitable washing liquid. Liquids may simply be water or special reagents or even suspensions to successfully remove unwanted gases, liquids or particles from the exhaust gas.



Exhaust gas washer to clean generated
process gases by washing out

Rotary Tube Furnaces for Continuous Processes up to 1300 °C



Rotary tube furnace RSRC 120/750/13

The RSRC rotary tube furnaces are particularly suitable for processes where continuously running batch material is heated for a short time.

The rotary tube furnace is positioned slightly inclined heated-up to the target temperature. The material is then continuously supplied at the upper end of the tube. It passes through the heated area of the tube and falls on the lower end out of the tube. The time of heat treatment results from the inclination angle, the rotational speed and the length of the working tube, as well as from the flow properties of the batch material.

Equipped with the optional closed loading system for 5 liter charge material incl. receptacle, the rotary tube furnace can also be used for processes under protective gas or vacuum.

Depending on process, charge and required maximum temperature, different working tubes made of quartz glass, ceramics or metal to be used. This rotary tube furnace is therefore highly adaptable for different processes.



Screw-conveyor with adjustable speed

- Tmax 1100 °C
 - Working tube made of quartz glass open at both sides
 - Thermocouple type K
- Tmax 1300 °C
 - Open tube made of ceramics C 530
 - Thermocouple type S
- Heating elements on support tubes provide for free radiation
- Housing made of sheets of textured stainless steel
- Adjustable drive of approx. 2-45 rpm
- Digital display unit for the tilting angle of the rotary tube furnace
- Beltless drive and split-type furnace housing (opening temperature < 180 °C) provide for very easy tube removal
- Compact system, rotary tube furnace positioned on a base frame with
 - manual spindle drive with crank to preset the tilting angle
 - switchgear and controls integrated
 - castors
- Defined application within the constraints of the operating instructions
- NTLog Basic for Nabertherm controller: recording of process data with USB-flash drive
- Controls description see page 72

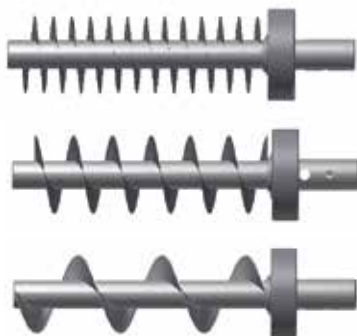

Screw-conveyors with different pitches for the adaption to the charge

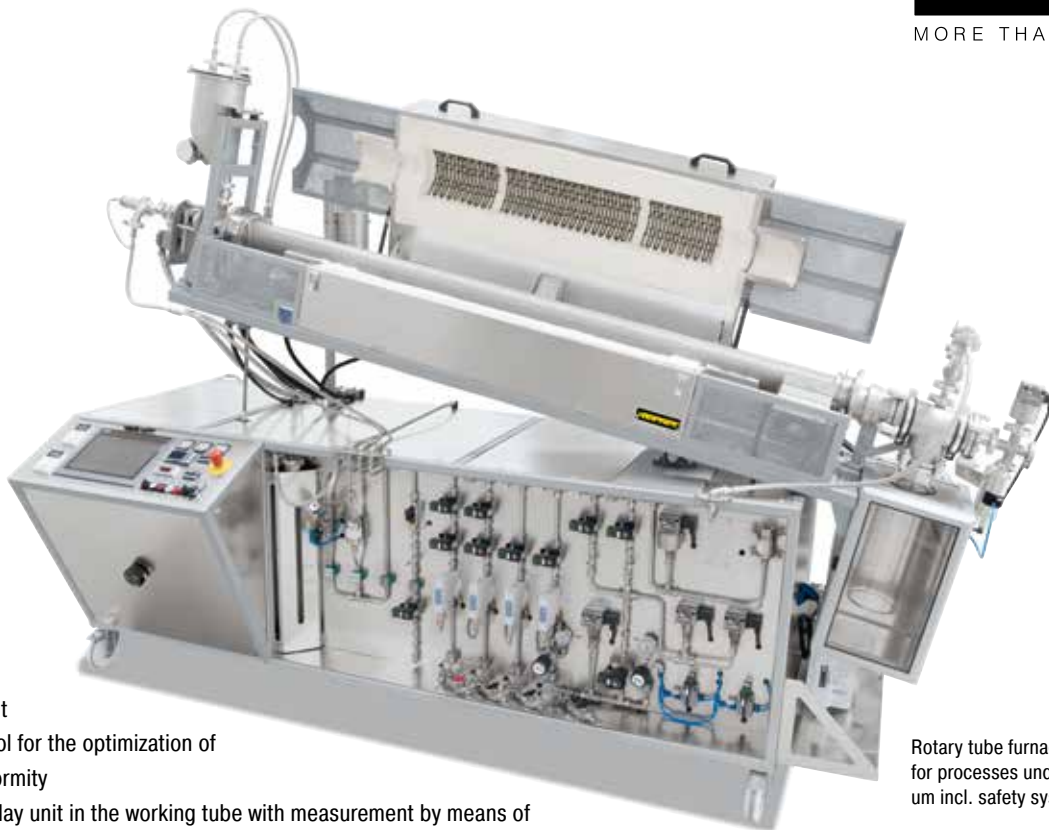

Additional equipment

- Three-zone control for the optimization of temperature uniformity
- Temperature display unit in the working tube with measurement by means of an additional thermocouple
- Charge control by means of an additional thermocouple in the working tube
- Different gassing systems with good flushing of the charge with process gas in counterflow (only in combination with feeding system below)
- Check valve at gas outlet avoids intrusion of false air
- Vacuum design, up to 10^{-2} mbar depending on the applied pump
- Charging system for continuous material transport, consisting of:
 - Stainless steel funnel incl. electric vibration generator to optimize the material feeding into the working tube
 - Electrically driven screw-conveyor at the inlet of the working tube with 10, 20 or 40 mm pitch and adjustable speed between 0.28 and 6 revolutions per minute, different gear transmissions for other speeds on request
 - Collecting bottle made of laboratory glass at the outlet of the working tube
 - Suitable for operation in gas atmosphere or vacuum
- Working tubes made of different materials
- Quartz glass batch reactors, T_{max} 1100 °C
- Higher temperatures up to 1600 °C available on request
- Digital display unit for the tilting angle of the furnace
- Electric linear drive for the adjustment of the tilting angle
- PLC controls for temperature control and the control of connected aggregates such as gearshift and speed of the screw-conveyor, speed of the working tube, switching of the vibration generator, etc.
- Process control and documentation via VCD software package or Nabertherm Control Center (NCC) for monitoring, documentation and control see page 72

Rotary tube furnace RSRC 120/1000/13 H₂ for processes under hydrogen or in vacuum incl. safety system



Adapters for alternative operation with working tube or process reactor



Vibration generator at the charging funnel for improved powder supply

Model	Tmax °C ³	Outer dimensions in mm			Max. outer tube Ø/ mm	Heated length mm	Length constant Temperature +/- 5 K in mm ³		Tube length in mm	Heating power in kW ⁴	Electrical connection*	Weight in kg
		W	D	H			single zoned	three zoned				
RSRC 80-500/11	1100	2505	1045	1655	80	500	170	250	1540	3.7	1-phase	555
RSRC 80-750/11	1100	2755	1045	1655	80	750	250	375	1790	4.9	3-phase ²	570
RSRC 120-500/11	1100	2505	1045	1715	110	500	170	250	1540	5.1	3-phase ²	585
RSRC 120-750/11	1100	2755	1045	1715	110	750	250	375	1790	6.6	3-phase ¹	600
RSRC 120-1000/11	1100	3005	1045	1715	110	1000	330	500	2040	9.3	3-phase ¹	605
RSRC 80-500/13	1300	2505	1045	1655	80	500	170	250	1540	6.3	3-phase ¹	555
RSRC 80-750/13	1300	2755	1045	1655	80	750	250	375	1790	9.6	3-phase ¹	570
RSRC 120-500/13	1300	2505	1045	1715	110	500	170	250	1540	8.1	3-phase ¹	585
RSRC 120-750/13	1300	2755	1045	1715	110	750	250	375	1790	12.9	3-phase ¹	600
RSRC 120-1000/13	1300	3005	1045	1715	110	1000	330	500	2040	12.9	3-phase ¹	605

¹Heating only between two phases

²Heating only between phase 1 and neutral

³Values outside the tube. Temperature inside the tube up to + 30 K

⁴Depending on furnace design connected load might be higher
*Please see page 73 for more information about supply voltage

Customized Tube Furnaces



Rotary Tube Furnace RSR 250/3500/15S



RS 460/1000/16S for integration in a production plant

With their high level of flexibility and innovation, Nabertherm offers the optimal solution for customer-specific applications.



RS 100/250/11S in split-type design for integration into a test stand

Based on our standard models, we develop individual solutions also for integration in overriding process systems. The solutions shown on this page are just a few examples of what is feasible. From working under vacuum or protective gas via innovative control and automation technology for a wide selection of temperatures, sizes, lengths and other properties of tube furnace systems – we will find the appropriate solution for a suitable process optimization.



RS 120/1000/11S in divided version. Both half furnaces are manufactured identically and will be integrated in an existing gas-heating system with space-saving design



RS 250/2500/11S, five-zone controlled, for wire annealing in high-vacuum or under protective gases, incl. forced cooling and exhaust hood

High-Temperature Tube Furnaces with SiC Rod Heating Gas Atmosphere or Vacuum



Tube furnace RHTC 80-230/15 with manual gas supply system

These compact tube furnaces with SiC rod heating and integrated switchgear and controller can be used universally for many processes. With an easy to replace working tube as well as additional standard equipment options, these furnaces are flexible and can be used for a wide range of applications. The high-quality fiber insulation ensures fast heating and cooling times. The SiC heating rods installed parallel to the working tube ensure excellent temperature uniformity. The price-performance ratio for this temperature range is unbeatable.

- Tmax 1500 °C
- Housing made of sheets of textured stainless steel
- High-quality fiber insulation
- Active cooling of housing for low surface temperatures
- Type S thermocouple
- Solid state relays provide for low-noise operation
- Prepared for assembly of working tubes with water-cooled flanges
- Ceramic tube, C 799 quality
- Defined application within the constraints of the operating instructions
- NTLog Basic for Nabertherm controller: recording of process data with USB-flash drive
- Controls description see page 72

Additional equipment

- Over-temperature limiter with adjustable cutout temperature for thermal protection class 2 in accordance with EN 60519-2 as temperature limiter to protect the furnace and load
- Charge control with temperature measurement in the working tube and in the furnace chamber outside the tube
- Fiber plugs
- Check valve at gas outlet avoids intrusion of false air
- Working tubes for operation with water-cooled flanges
- Display of inner tube temperature with additional thermocouple
- Alternative gas supply systems for protective gas or vacuum operation
- Process control and documentation via VCD software package for monitoring, documentation and control see page 72



For further information about tube furnaces please ask for our separate laboratory catalog!

Model	Tmax °C ³	Outer dimensions in mm			Outer tube Ø in mm	Heated length in mm	Length constant temperature +/- 5 K in mm ³	Tube length in mm	Heating power in kW ⁴	Electrical connection*	Weight in kg
		W	D	H							
RHTC 80-230/15	1500	600	430	580	80	230	80	600	7.5	3-phase ²	50
RHTC 80-450/15	1500	820	430	580	80	450	150	830	11.3	3-phase ¹	70
RHTC 80-710/15	1500	1075	430	580	80	710	235	1080	13.8	3-phase ¹	90

¹Heating only between two phases

²Heating only between phase 1 and neutral

³Values outside the tube. Temperature inside the tube up to + 30 K

⁴Depending on furnace design connected load might be higher

*Please see page 73 for more information about supply voltage

Float-Glass Test Kiln with Wire Heating



This chamber furnace was designed to test different types of glass plates such as fire protection glass. In addition to the kiln door, there is a second frame which can be swung in front of the work space into which the test plate is placed. This door is fixed with a special mechanism. The furnace chamber is flat and is heated by element coils supported on ceramic support tubes mounted only on the back wall so that the heat radiates directly onto the glass surface. The chamber furnace achieves exceptionally short cycle times due to the very small chamber volume and high power input.

Model	Tmax °C	Inner dimensions in mm			Volume in l	Outer dimensions in mm			Heating power in kW ¹	Electrical connection*	Weight in kg
		w	d	h		W	D	H			
N 40/14	1400	400	150	600	36	1000	600	1800	36	3-phase	250

¹Depending on furnace design connected load might be higher *Please see page 73 for more information about supply voltage

Laboratory Melting Furnace SC 8 with SiC Rod Heating



Laboratory melting furnace SC 8 with SiC rod heating for use with a customer crucible



Two-side heating with SiC rods

The laboratory melting furnace SC 8 was specially developed for melting glass in the laboratory. A customer crucible is entered into the furnace from the top. Glass is molten in the crucible. Heating is realized from two sides with powerful SiC rods. With this heating method a maximum furnace temperature of 1500 °C can be achieved. The very effective, multi-layer insulation with long-life lightweight refractory bricks inside the chamber guarantees low outside temperatures even if the furnace is in continuously used.

Model	Tmax °C	Inner dimensions in mm			Volume in l	Outer dimensions in mm			Heating power in kW ¹	Electrical connection*	Weight in kg
		w	d	h		W	D	H			
SC 8	1500	200	150	250	8	840	715	730	30	3-phase	290

¹Depending on furnace design connected load might be higher *Please see page 73 for more information about supply voltage

Fast-Firing Decorating Furnaces with Infrared Heating



Fast-firing decorating furnace IR 500/90 with alternating table system for firing transfer prints

The fast-firing decorating furnaces with infrared heating are especially suitable for decal firing of glass or ceramics at working temperatures up to 900 °C. The fast-firing decorating furnace is equipped with two manually movable tables on castors for easy handling. Both tables and the furnace chamber are insulated with non-classified fiber materials. With the fiber insulation in combination with the infrared heating, which provides for a fast surface heating, the furnace achieves particularly short process cycles.

Depending on the charge type the tables may be charged in several layers what allows for an optimal use of the available space. The charge surface with applied decal should face towards the heating elements which are positioned in the roof. While one charged table is positioned in the fast-firing decorating furnace the other table can already be charged outside the furnace. If the charge permits, the table with still warm charge can be driven out of the furnace and the other table is pushed into the furnace to use the residual energy.

To vent the exhaust gases generated during decor firing, the furnace is equipped with a motor-driven exhaust gas flap which can be activated via the controls. The stainless steel exhaust hood which is positioned above the motor-driven flap will be connected to customer's ductwork.

- Infrared heating elements in the roof with reflectors installed on each table
- Insulation made of non-classified fiber materials provides for fast process cycles
- Process times of hardly three hours from cold to cold possible, depending on the charge and the working temperature
- Alternating table system on castors, very easy to move
- Motorized exhaust-gas flap on top of the furnace with stainless steel exhaust hood
- Easy-to-operate controls
- Defined application within the constraints of the operating instructions
- NTLog Basic for Nabertherm controller: recording of process data with USB-flash drive
- Controls description see page 72



Infrared heating from the top



Glassware to be decorated



Charging trolley for disc coating

Model	Tmax °C	Inner dimensions in mm			Volume in l	Outer dimensions in mm			Heating power in kW ¹	Electrical connection*	Weight in kg
		w	d	h		W	D	H			
IR 500/90	900	1600	900	350	500	6000	1400	1300	36	3-phase	1100
IR 1000/90	900	3200	900	350	1000	12000	1400	1300	72	3-phase	2000

¹Depending on furnace design connected load might be higher

*Please see page 73 for more information about supply voltage

Glass Melting Furnaces

Electrically Heated



Glass melting furnace GM 50

The glass melting furnaces product line GM are used as day container. SiC rod heating in the furnace roof provide for fast heating times. A robust chamber insulation of refractory bricks in the bottom and non-classified fiber in the roof allows efficient working with low power consumption. Molten glass can be removed through the pneumatic lift-door out of the crucible (option) by means of a pipe.



Crucible in glass melting furnace

- Tmax 1350 °C
- Standard size for 50 kg and 200 kg glass
- Fully automatic temperature control
- SiC heating elements with high power output
- Silent operation
- Insulation is structured in multi-layer lightweight refractory bricks and a special backing insulation
- Pneumatic lift door with opening 200 mm x 300 mm and foot pedal
- Easy opening of hood for maintenance or crucible exchange
- Glass melting furnace on robust transport wheels
- Defined application within the constraints of the operating instructions
- NTLog Basic for Nabertherm controller: recording of process data with USB-flash drive
- Controls description see page 72

Additional equipment

- Process control and documentation via VCD software package for monitoring, documentation and control see page 75

Model	Tmax °C	Inner dimensions crucible		Volume in l	Outer dimensions in mm			Heating power in kW ¹	Electrical connection*	Weight in kg
		Ø in mm	h in mm		W	D	H			
GM 50	1350	368	216	55	1320	1150	1680	9	3-phase	500
GM 200	1350	650	400	200	1610	1450	1880	30	3-phase	650

¹Depending on furnace design connected load might be higher

*Please see page 73 for more information about supply voltage

Temperature Uniformity and System Accuracy

Temperature uniformity is defined as the maximum temperature deviation in the work space of the furnace. There is a general difference between the furnace chamber and the work space. The furnace chamber is the total volume available in the furnace. The work space is smaller than the furnace chamber and describes the volume which can be used for charging.

Specification of Temperature Uniformity in +/- K in the Standard Furnace

In the standard design the temperature uniformity is specified in +/- K at a defined set-temperature with the work space of the empty furnace during the dwell time. In order to make a temperature uniformity survey the furnace should be calibrated accordingly. As standard our furnaces are not calibrated upon delivery.

Calibration of the Temperature Uniformity in +/- K

If an absolute temperature uniformity at a reference temperature or at a defined reference temperature range is required, the furnace must be calibrated appropriately. If, for example, a temperature uniformity of +/- 5 K at a set temperature of 750 °C is required, it means that measured temperatures may range from a minimum of 745 °C to a maximum of 755 °C in the work space.

System Accuracy

Tolerances may occur not only in the work space, they also exist with respect to the thermocouple and in the controls. If an absolute temperature uniformity in +/- K at a defined set temperature or within a defined reference working temperature range is required, the following measures have to be taken:

- Measurement of total temperature deviation of the measurement line from the controls to the thermocouple
- Measurement of temperature uniformity within the work space at the reference temperature or within the reference temperature range
- If necessary, an offset is set at the controls to adjust the displayed temperature at the controller to the real temperature in the furnace
- Documentation of the measurement results in a protocol

Temperature Uniformity in the Work Space incl. Protocol

In standard furnaces a temperature uniformity is guaranteed as +/- K without measurement of temperature uniformity. However, as additional feature, a temperature uniformity measurement at a reference temperature in the work space compliant with DIN 17052-1 can be ordered. Depending on the furnace model, a holding frame which is equivalent in size to the work space is inserted into the furnace. This frame holds thermocouples at 11 defined measurement positions. The measurement of the temperature uniformity is performed at a reference temperature specified by the customer at a pre-defined dwell time. If necessary, different reference temperatures or a defined reference working temperature range can also be calibrated.



Holding frame for measurement of temperature uniformity



Pluggable frame for measurement for forced convection chamber furnace N 7920/45 HAS



The system accuracy is defined by adding the tolerances of the controls, the thermocouple and the work space

Precision of the controls, e.g. +/- 1 K

Deviation of thermocouple, e.g. +/- 1.5 °C

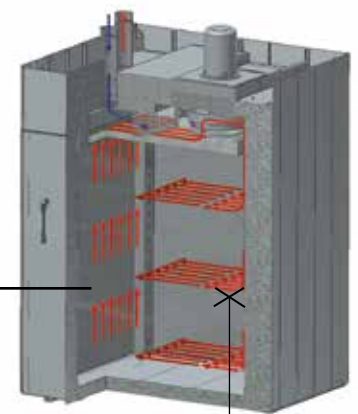

Deviation from measuring point to the average temperature in the work space e.g. +/- 3 °C

Process Control and Documentation



B400/C440/P470



B410/C450/P480



H1700 with colored, tabular depiction



H3700 with colored graphic presentation

Nabertherm has many years of experience in the design and construction of both standard and custom control alternatives. All controls are remarkable for their ease of use and even in the basic version have a wide variety of functions.

Standard Controllers

Our extensive line of standard controllers satisfies most customer requirements. D60Based on the specific furnace model, the controller regulates the furnace temperature reliably and is equipped with an integrated USB-interface for documentation of process data (NTLog/NTGraph).

The standard controllers are developed and fabricated within the Nabertherm group. When developing controllers, our focus is on ease of use. From a technical standpoint, these devices are custom-fit for each furnace model or the associated application. From the simple controller with an adjustable temperature to the control unit with freely configurable control parameters, stored programs and PID microprocessor control with self-diagnosis system, we have a solution to meet your requirements.

HiProSystems Control and Documentation

This professional process control with PLC controls for single and multi-zone furnaces is based on Siemens hardware and can be adapted and upgraded extensively. HiProSystems control is used when more than two process-dependent functions, such as exhaust air flaps, cooling fans, automatic movements, etc., have to be handled during a cycle, when furnaces with more than one zone have to be controlled, when special documentation of each batch is required and when remote service is required. It is flexible and is easily tailored to your process or documentation needs.

Alternative User Interfaces for HiProSystems

Process control H500/H700

This basic panel accommodates most basic needs and is very easy to use. Firing cycle data and the extra functions activated are clearly displayed in a table. Messages appear as text. Data can be stored on a USB stick using the „NTLog Comfort“ option (not available for all H700).

Process control H1700

Customized versions can be realized in addition to the scope of services of the H500/H700

Process control H3700

Display of functions on a large 12“ display. Display of basic data as online trend or as a graphical system overview. Scope as H1700

Control, Visualisation and Documentation with Nabertherm Control Center NCC

Upgrading the HiProSystems-Control individually into a PC-based NCC provides for additional interfaces, operating documentation, and service benefits in particular for controlling furnace groups including charge beyond the furnace itself (quenching tank, cooling station etc.):

- Recommended for heat treatment processes with extensive requirements in respect to documentation e.g. for metals, technical ceramics or in the medicine field
- Software extension can be used also in accordance with the AMS 2750 E (NADCAP)
- Documentation according to the requirements of Food and Drug Administration (FDA), Part 11, EGV 1642/03 possible
- Charge data can be read in via barcodes
- Interface for connection to overriding systems
- Connection to mobile phone or stationary network for malfunction message transmission via SMS
- Control from various locations over the network
- Measurement range calibration up to 18 temperatures per measuring point for use at different temperatures. For norm-relevant applications a multilevel calibration is possible.

Assignment of Standard Controllers to Furnace Families	W .. A	KTR	TR	TR .. LS	NA 30/45 - N 675/85 HA	W	W ..DB	WHTC	N ..G - N 2200/14	N 100 - N 2200/H	LH	H .. /LB oder LT	HC	HT	HTC 16/16 - HTC 450/16	HFL	HTB	HT .. /LB oder LT	TS .. /50	N 7/H - N 87 .. /H .. /HR	N 81(..) - N 641(..)	GF, GFM	GW	HG	NRA 17/06 - NRA 1000/11	NR, NRA .. H ₂	NR, NRA .. IDB	SRA	(S/LB) VHT	(S/LB) SVHT .. /H ₂	RSRC	RHTC	N 40/14	SC 8	IR	GM 50				
Catalog page	4	8	12	12	14	16	16	18	20	20	22	24	26	28	31	32	33	34	42	43	43	44/46	48	50	52	54	54	55	56	58	64	67	68	68	69	70				
Controller																																								
R7			●																																					
B400	●	●			●				●	●										●	●																	●		
B410																																								
C440	○	○	○		○				○	○	○									○	○																			
C450				●																																				
P470	○	○	○		○	●	● ³	● ³	●	○	○	●	●	● ³	● ³	● ³	●	● ³		○	○	○		● ³	●			●	● ³								●			
P480			○																																					
3208/C6		○	○		○	○	○	○	○	○	○	○	○	○	○	○	○	○	○	○	○	○	○	○	○	○	○	○	○	○	○	○	○	○	○	○	○	○	○	
3504		○	○		○	○	○	○	○	○	○	○	○	○	○	○	○	○	○	○	○	○	○	○	○	○	○	○	○	○	○	○	○	○	○	○	○	○	○	
H500/SPS					○	○	○	○	○	○	○	○	○	○	○	○	○	○	○	○	○	○	○	○	○	○	○	○	○	○	○	○	○	○	○	○	○	○	○	
H700/SPS					○	○	○	○	○	○	○	○	○	○	○	○	○	○	○	○	○	○	○	○	○	○	○	○	○	○	○	○	○	○	○	○	○	○	○	○
H1700/SPS		○	○		○	○	○	○	○	○	○	○	○	○	○	○	○	○	○	○	○	○	○	○	○	○	○	○	○	○	○	○	○	○	○	○	○	○	○	○
H3700/SPS	○	○	○		○	○	○	○	○	○	○	○	○	○	○	○	○	○	○	○	○	○	○	○	○	○	○	○	○	○	○	○	○	○	○	○	○	○	○	○
NCC	○	○	○		○	○	○	○	○	○	○	○	○	○	○	○	○	○	○	○	○	○	○	○	○	○	○	○	○	○	○	○	○	○	○	○	○	○	○	○

Functionality of the Standard Controllers

	R7	C6	3216	3208	B400/ B410	C440/ C450	P470/ P480	3504	H500	H700	H1700	H3700	NCC
Number of programs	1	1	1		5	10	50	25	20	1/10 ³	10	10	50
Segments	1	2	8		4	20	40	500 ³	20	20	20	20	20
Extra functions (e.g. fan or autom. flaps) maximum					2	2	2-6	2-8 ³	3 ³	○ ³	6/2 ³	8/2 ³	16/4 ³
Maximum number of control zones	1	1	1	1	1	1	3	2 ^{1,2}	1-3 ³	○ ³	8	8	8
Drive of manual zone regulation					●	●	●		○	○	○	○	○
Charge control/bath control							●	○	○	○	○	○	○
Auto tune			●	●	●	●	●	●					
Real-time clock					●	●	●		●	●	●	●	●
Plain, blue-white LC-display					●	●	●						●
Graphic color display									4" 7"	7"	7"	12"	19"
Status messages in clear text				●	●	●	●	●	●	●	●	●	●
Data entry via touchpanel									●	●	●	●	●
Data input via jog dial and buttons					●	●	●		●	●	●	●	●
Entering program names (i.e. "Sintering")					●	●	●						●
Keypad lock					●	●	●	●					●
User administration					●	●	●	●					●
Skip-button for segment jump					●	●	●	●	○	○	○	○	●
Program entry in steps of 1 °C or 1 min.	●		●	●	●	●	●	●	●	●	●	●	●
Start time configurable (e.g. to use night power rates)			●	●	●	●	●	●	●	●	●	●	●
Switch-over °C/°F	○		○	○	●	●	●	○	●	● ³	● ³	● ³	● ³
kWh meter					●	●	●	●					●
Operating hour counter					●	●	●	●	●	●	●	●	●
Set point output				○	●	●	●	○		○	○	○	○
NTLog Comfort for HiProSystems: Recording of process data on an external storage medium									○	○	○	○	
NTLog Basic for Nabertherm controller: recording of process data with USB-flash drive					●	●	●						
Interface for VCD software					○	○	○						
Malfunction memory					●	●	●	●	●	●	●	●	●

¹ Not for melt bath control
² Control of additional separate slave regulators possible
³ Depending on the design

● Standard
○ Option

Mains Voltages for Nabertherm Furnaces

1-phase: all furnaces are available for mains voltages from 110 V - 240 V at 50 or 60 Hz.
 3-phase: all furnaces are available for mains voltages from 200 V - 240 V or 380 V - 480 V, at 50 or 60 Hz.
 The connecting rates in the catalog refer to the standard furnace with 400 V (3/N/PE) respectively 230 V (1/N/PE).

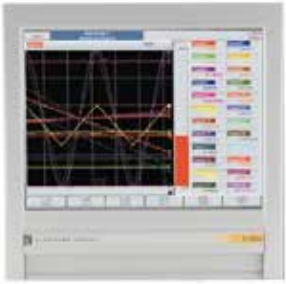

Temperature recorder

Temperature Recorder

Besides the documentation via the software which is connected to the controls, Nabertherm offers different temperature recorders which can be used with respect to the application.

	Model 6100e	Model 6100a	Model 6180a
Data input using touch panel	X	X	X
Size of colour display in inch	5.5	5.5	12.1
Number of thermocouple inputs	3	18	48
Data read-out via USB-stick	X	X	X
Input of charge data		X	X
Evaluation software included	X	X	X
Applicable for TUS-measurements acc. to AMS 2750 E			X



Data storing of Nabertherm controllers with NTLog Basic

NTLog Basic allows for recording of process data of the connected Nabertherm Controller (B400, B410, C440, C450, P470, P480) on a USB stick.

The process documentation with NTLog Basic requires no additional thermocouples or sensors. Only data recorded which are available in the controller.



The data stored on the USB stick (up to 80,000 data records, format CSV) can afterwards be evaluated on the PC either via NTGraph or a spreadsheet software used by the customer (e.g. MS Excel).

For protection against data manipulation the generated data records contain checksums.



NTLog Comfort for data recording of a Siemens PLC

Data storing of HiProSystems with NTLog Comfort

The extension module NTLog Comfort offers the same functionality of NTLog Basic module. Process data from a HiProSystems control are read out and stored in real time on a USB stick (not available for all H700 systems). The extension module NTLog Comfort can also be connected using an Ethernet connection to a computer in the same local network so that data can be written directly onto this computer.

Visualization with NTGraph

The process data from NTLog can be visualized either using the customer's own spreadsheet program (e.g. MS-Excel) or NTGraph (Freeware). With NTGraph Nabertherm provides for a user-friendly tool free of charge for the visualization of the data generated by NTLog. Prerequisite for its use is the installation of the program MS Excel for Windows (version 2003/2010/2013). After data import presentation as diagram, table or report can be chosen. The design (color, scaling, reference labels) can be adapted by using prepared sets.

NTGraph is available in seven languages (DE/EN/FR/SP/IT/CH/RU). In addition, selected texts can be generated in other languages.

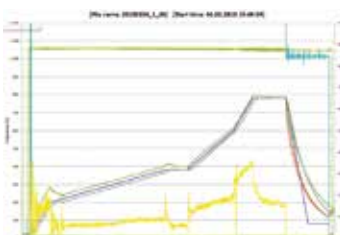

NTGraph, a freeware for the easy-to-read analysis of recorded data using MS Excel

VCD-Software for Visualization, Control and Documentation

Documentation and reproducibility are more and more important for quality assurance. The powerful VCD software represents an optimal solution for single multi furnace systems as well as charge documentation on the basis of Nabertherm controllers.

The VCD software is used to record process data from the controllers B400/B410, C440/C450 and P470/P480. Up to 400 different heat treatment programs can be stored. The controllers are started and stopped via the software. The process is documented and archived accordingly. The data display can be carried-out in a diagram or as data table. Even a transfer of process data to MS Excel (.csv format *) or the generation of reports in PDF format is possible.



VCD Software for Control, Visualisation and Documentation

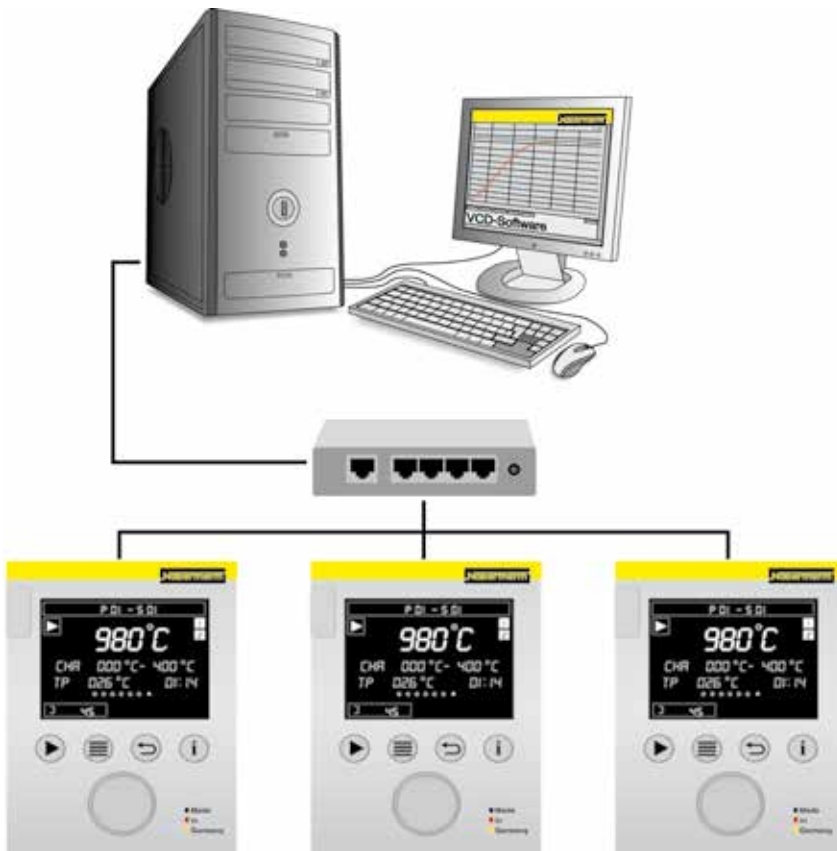

Example lay-out with 3 furnaces

Features

- Available for controllers B400/B410/C440/C450/P470/P480
- Suitable for operating systems Microsoft Windows 7 (32/64 Bit) or 8/8.1 (32/64 Bit)
- Simple installation
- Setting, Archiving and print of programs and graphics
- Operation of controllers via PC
- Archiving of process curves from up to 16 furnaces (also multi-zone controlled)
- Redundant saving of archives on a server drive
- Higher security level due to binary data storage
- Free input of charge date with comfortable search function
- Possibility to evaluate data, files can be converted to Excel
- Generation of a PDF-report
- 17 languages selectable

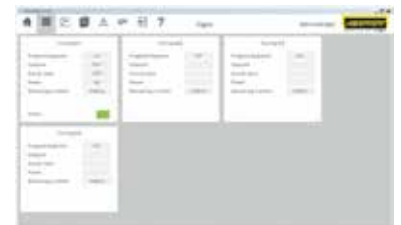

Graphic display of main overview (version with 4 furnaces)

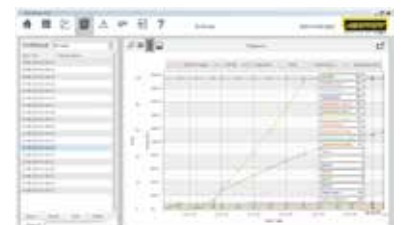

Graphic display of process curve

The whole World of Nabertherm: www.nabertherm.com

Please visit our website

www.nabertherm.com and find out all you want to know about us - and especially about our products.

Besides news and our current calendar of trade fairs, there is also the opportunity to get in touch directly with your local sales office or nearest dealer worldwide.

Professional Solutions for:

- Arts & Crafts
- Glass
- Advanced Materials
- Laboratory
- Dental
- Thermal Process Technology for Metals, Plastics and Surface Finishing
- Foundry



Headquarters:

Nabertherm GmbH
Bahnhofstr. 20
28865 Lilienthal, Germany
contact@nabertherm.de

Sales Organisation

China
Nabertherm Ltd. (Shanghai)
150 Lane, No. 158 Pingbei Road, Minhang District
201109 Shanghai, China
contact@nabertherm-cn.com

France
Nabertherm SARL
35 Allée des Impressionnistes - BP 44011
95911 Roissy CDG Cedex, France
contact@nabertherm.fr

Italy
Nabertherm Italia
via Trento N° 17
50139 Florence, Italy
contact@nabertherm.it

Great Britain
Nabertherm Ltd., United Kingdom
contact@nabertherm.com

Switzerland
Nabertherm Schweiz AG
Altgraben 31 Nord
4624 Härkingen, Switzerland
contact@nabertherm.ch

Spain
Nabertherm España
c/Marti i Julià, 8 Bajos 7ª
08940 Cornellà de Llobregat, Spain
contact@nabertherm.es

USA
Nabertherm Inc.
54 Read's Way
New Castle, DE 19720, USA
contact@nabertherm.com

All other Countries: Follow
<http://www.nabertherm.com/contacts>

